

Four-row linear recirculating ball bearing and guideway assemblies

Full complement

Standard, L, N and NL carriages

Dimension table · Dimensions in mm															
Designation	Dimensions				Mounting dimensions										
	$l_{\max}^{2)}$	H	B	L	A_1	J_B	b	A_2	L_1	L_S	J_L	J_{LZ}	j_L	$a_L, a_R^{3)}$	
							$-0,005$ $-0,03$							min.	max.
KUVE15-B	2 880	24	47	61,2	16	38	15	4,5	39,8	1,3	30	26	60	20	53
KUVE20-B	5 880	30	63	71,4	21,5	53	20	5	50,4	1,3	40	35	60	20	53
KUVE20-B-L				88,9					67,9						
KUVE20-B-N		71,4		50,4											
KUVE20-B-NL		88,9		67,9											
KUVE25-B	5 880	36	70	83,3	23,5	57	23	6,5	60,7	1,65	45	40	60	20	53
KUVE25-B-L				109,1					86,5						
KUVE25-B-N		83,3		60,7											
KUVE25-B-NL		109,1		86,5											
KUVE30-B	5 860	42	90	99	31	72	28	9	72	1,65	52	44	80	20	71
KUVE30-B-L				127					100						
KUVE30-B-N		99		72											
KUVE30-B-NL		127		100											
KUVE35-B	5 860	48	100	112	33	82	34	9	80	1,65	62	52	80	20	71
KUVE35-B-L				145					113						
KUVE35-B-N		112		80											
KUVE35-B-NL		145		113											
KUVE45-B	5 835	60	120	140,6	37,5	100	45	10	102,5	2,2	80	60	105	20	94
KUVE45-B-L				172,7					134,6						
KUVE45-B-N		140,6		102,5											
KUVE45-B-NL		172,7		134,6											
KUVE55-B	5 820	70	140	173,6	43,5	116	53	12	132	2,2	95	70	120	20	107
KUVE55-B-L				211,6					170						

For further table values, see page 314 and page 315.

① Locating face. ② Marking.

- The stated torques represent maximum values for the secure transmission of forces in vibration-free, quasistatic applications ($S_0 = 1$). We recommend that the tightening torques for the screw connection of the adjacent construction should be determined at the customer under the conditions specific to the application and operation, observing the information in VDI Guideline 2230 Part 1 (2015) and the information in this description, see page 69 and page 26.
- Maximum length of single-piece guideways.
Permissible number of guideway segments, see page 309.
- a_L and a_R are dependent on the guideway length.

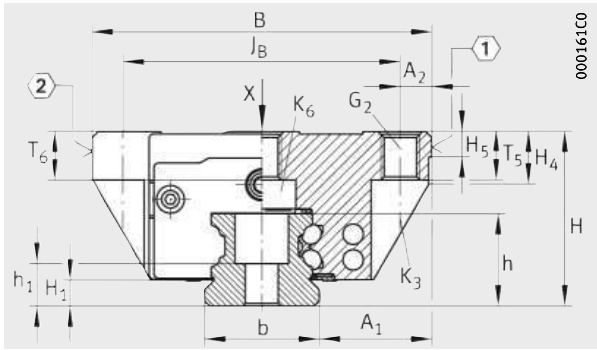

KUVE...-B, KUVE...-B-L, KUVE...-B-N, KUVE...-B-NL

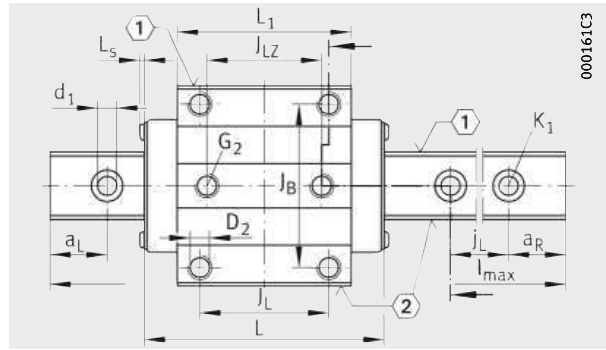

KUVE...-B, KUVE...-B-L, KUVE...-B-N, KUVE...-B-NL
View X rotated 90°

Fixing screws ¹⁾																		
H ₁	H ₄	H ₅	T ₅	T ₆	h	h ₁	DIN ISO 4762-12.9				DIN 7984-8.8				d ₁	D ₂		
							G ₂	M _A	K ₁	M _A	K ₃	M _A	K ₆	M _A				
							Nm	Nm	Nm	Nm	Nm	Nm						
4,3	7,6	4,75	7	5,8	15	7,6	M5	5,8	M4	5	M4	5	-	-	M4	2	4,6	4,5
4,5	11	5,25	10	7,5	17	8,6	M6	10	M5	10	M5	10	M5	10	-	-	5,8	5,5
	8,6		8	6							M5	10	-	-	M5	4		
5,1	10,9	5,25	10	10	18,7	8,2	M8	24	M6	17	M6	17	M6	17	-	-	6,8	6,7
	9,3			8									-	-	M6	8		
5,9	13,8	6,25	12	11,5	23,5	11	M10	41	M8	41	M8	41	M8	41	-	-	9	8,6
	9,8			9									-	-	M8	12		
6,7	14,3	6,75	13	12,3	27	14,5	M10	41	M8	41	M8	41	M8	41	-	-	9	8,6
	10,3			8,3									-	-	M8	12		
9,7	19,9	9,25	15	15	34,2	15,7	M12	83	M12	140	M10	83	M10	83	-	-	13,4	10,6
	17,2			11									-	-	M10	35		
13,5	22,7	11,25	21	18	41,5	19	M14	140	M14	220	M12	140	M12	140	-	-	15,4	12,5

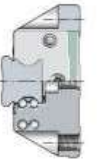

Four-row linear recirculating ball bearing and guideway assemblies

Full complement
Standard, L, N and NL carriages

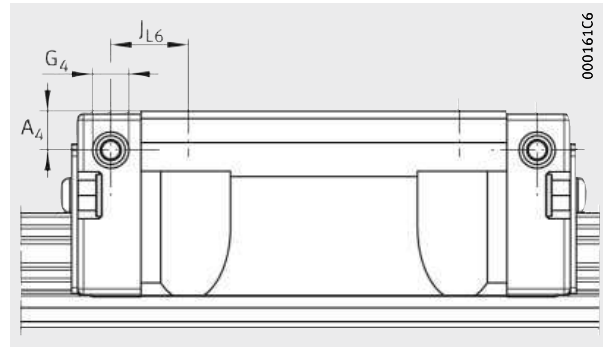

Lubrication connector on lateral face

Dimension table (continued) · Dimensions in mm

Designation	Carriage		Guideway		Lubrication connectors		
	Designation	Mass m ≈ kg	Designation	Mass m ≈ kg/m	A ₃	G ₃	2)
KUVE15-B	KWVE15-B	0,2	TKVD15-B ³⁾	1,44	4,3	M3	5,5
KUVE20-B	KWVE20-B	0,44	TKVD20	2,2	7,7	M5	7
KUVE20-B-L	KWVE20-B-L	0,59			4,7		
KUVE20-B-N	KWVE20-B-N	0,37					
KUVE20-B-NL	KWVE20-B-NL	0,51					
KUVE25-B	KWVE25-B	0,68	TKVD25	2,7	11	M6	7
KUVE25-B-L	KWVE25-B-L	1			6		
KUVE25-B-N	KWVE25-B-N	0,56					
KUVE25-B-NL	KWVE25-B-NL	0,82					
KUVE30-B	KWVE30-B	1,2	TKVD30	4,3	11,5	M6	7
KUVE30-B-L	KWVE30-B-L	1,7			7,5		
KUVE30-B-N	KWVE30-B-N	1					
KUVE30-B-NL	KWVE30-B-NL	1,5					
KUVE35-B	KWVE35-B	1,75	TKVD35	5,7	12,3	M6	7
KUVE35-B-L	KWVE35-B-L	2,52			8,3		
KUVE35-B-N	KWVE35-B-N	1,56					
KUVE35-B-NL	KWVE35-B-NL	2,23					
KUVE45-B	KWVE45-B	3,3	TKVD45	9,2	16,5	M6	7
KUVE45-B-L	KWVE45-B-L	4,3			8,5		
KUVE45-B-N	KWVE45-B-N	2,72					
KUVE45-B-NL	KWVE45-B-NL	3,38					
KUVE55-B	KWVE55-B	5,5	TKVD55-B	14	15	M6	7
KUVE55-B-L	KWVE55-B-L	6,6					

- 1) Calculation of basic load ratings in accordance with DIN ISO 14728-1.
Based on practical experience, it may be possible to increase the basic dynamic load rating.
The basic load rating can only be transmitted fully if the whole thread length is used and the adjacent construction is dimensioned appropriately.
- 2) Maximum permissible screw depth for lubrication connectors.
- 3) The new carriages cannot be used on the previous guideways TKVD15 or TKVD15-U.
- 4) Lubrication connectors are included loose:
 - S04 with KUVE20-B
 - S05 with KUVE25-B to KUVE55-B
 - S16 with KUVE15-B.

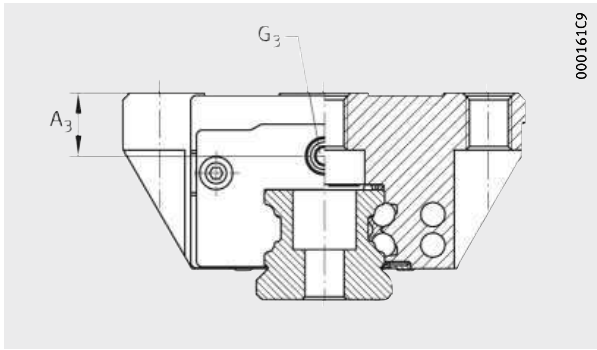

Lubrication connector on end face

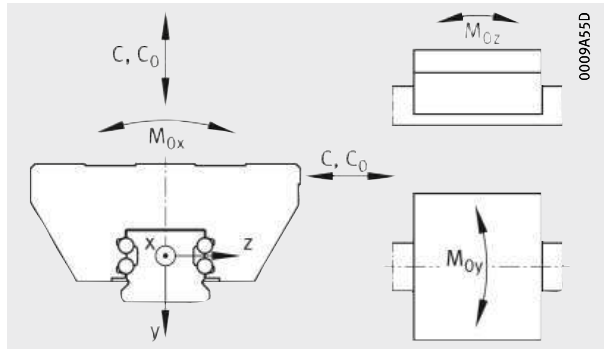

Load directions

			Load carrying capacity					
A ₄	G ₄	2)	J _{L6}	Basic load ratings ¹⁾		Moment ratings		
				dyn. C N	stat. C ₀ N	M _{0x} Nm	M _{0y} Nm	M _{0z} Nm
3,2	M3	5,5	9,1	7 200	14 500	150	100	100
4,6	M5	5,5	9,4	13 100	27 000	332	240	240
			18,9	16 200	36 500	452	430	430
3,3	M3		9,4	13 100	27 000	332	240	240
			18,9	16 200	36 500	452	430	430
6,5	M6	7	12,85	17 900	37 000	510	395	395
			25,75	23 400	54 000	745	825	825
4	M3	6	12,05	17 900	37 000	510	395	395
			24,95	23 400	54 000	745	825	825
7	M6	7	15,5	27 500	55 000	970	700	700
			29,5	34 500	74 000	1 310	1 240	1 240
4,95	M5		15,1	27 500	55 000	970	700	700
			29,1	34 500	74 000	1 310	1 240	1 240
11	M6	7	16	38 000	72 000	1 465	1 020	1 020
			32,5	47 500	100 000	2 625	1 890	1 890
7			16	38 000	72 000	1 465	1 020	1 020
			32,5	47 500	100 000	2 625	1 890	1 890
16,5	M6	7	19,25	69 000	141 000	3 610	2 485	2 485
			35,3	82 000	181 000	4 635	4 000	4 000
8,5			19,25	69 000	141 000	3 610	2 485	2 485
			35,5	82 000	181 000	4 635	4 000	4 000
15	M6	7	30,5	104 000	213 000	5 600	2 730	2 730
			49,5	127 000	285 000	7 500	4 725	4 800

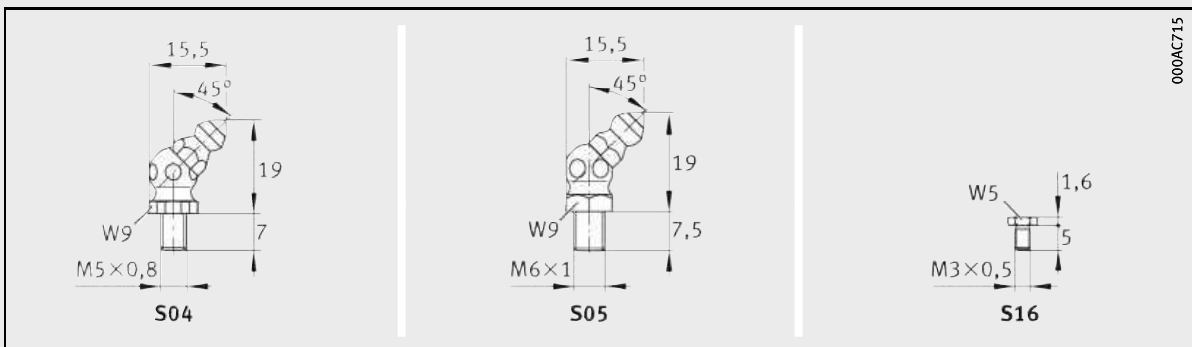
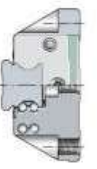

Lubrication connectors⁴⁾

Four-row linear recirculating ball bearing and guideway assemblies

Full complement
H, S and SN carriages

Dimension table · Dimensions in mm											
Designation	Dimensions				Mounting dimensions						
	$l_{\max}^{2)}$	H	B	L	A_1	J_B	b <small>-0,005 -0,03</small>	A_2	L_1	L_S	J_L
KUVE15-B-H	2 880	28	34	61,2	9,5	26	15	4	39,8	1,3	26
KUVE15-B-S		24									
KUVE20-B-H ⁴⁾	5 880	30	44	71,4	12	32	20	6	50,4	1,3	36
KUVE20-B-S ⁴⁾		30									
KUVE20-B-SN		27									
KUVE25-B-H	5 880	40	48	83,3	12,5	35	23	6,5	60,7	1,65	35
KUVE25-B-S		36									
KUVE25-B-SN		31									
KUVE30-B-H	5 860	45	60	99	16	40	28	10	72	1,65	40
KUVE30-B-S		42									
KUVE30-B-SN		38									
KUVE35-B-H	5 860	55	70	112	18	50	34	10	80	1,65	50
KUVE35-B-S		48									
KUVE35-B-SN		44									
KUVE45-B-H	5 835	70	86	140,6	20,5	60	45	13	102,5	2,2	60
KUVE45-B-S		60									
KUVE45-B-SN		52									
KUVE55-B-S	5 820	70	100	173,6	23,5	75	53	12,5	132	2,2	75

For further table values, see page 318 and page 319.

① Locating face. ② Marking.

- 1) The stated torques represent maximum values for the secure transmission of forces in vibration-free, quasistatic applications ($S_0 = 1$). We recommend that the tightening torques for the screw connection of the adjacent construction should be determined at the customer under the conditions specific to the application and operation, observing the information in VDI Guideline 2230 Part 1 (2015) and the information in this description, see page 69 and page 26.
- 2) Maximum length of single-piece guideways.
Permissible number of guideway segments, see page 309.
- 3) a_L and a_R are dependent on the guideway length.
- 4) KUVE20-B-H and KUVE20-B-S are 100% identical in dimensions and performance.
If a KUVE20-B-H is ordered, the order confirmation will contain the designation KUVE20-B-S.

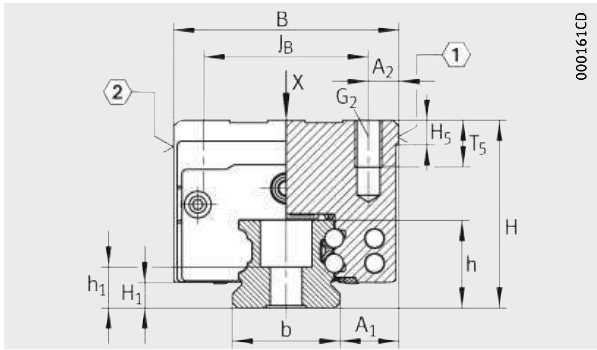

KUVE...-B-H, KUVE...-B-S, KUVE...-B-SN

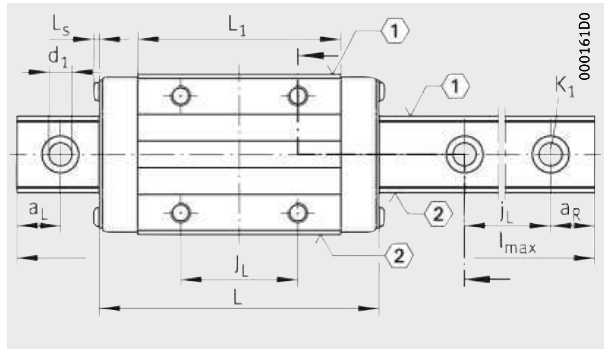

KUVE...-B-H, KUVE...-B-S, KUVE...-B-SN
View X rotated 90°

j _L	a _L , a _R ³⁾		H ₁	H ₅	T ₅	h	h ₁	Fixing screws ¹⁾				d ₁	
								DIN ISO 4762-12.9		G ₂	K ₁		
								min.	max.		M _A Nm		M _A Nm
60	20	53	4,3	4,75	6	15	7,6	M4	5	M4	5	4,6	
60	20	53	4,5	5,25	7,5	17	8,6	M5	10	M5	10	5,8	
60	20	53	5,1	5,25	10	18,7	8,2	M6	17	M6	17	6,8	
					7,5								
80	20	71	5,9	6,25	13,5	23,5	11	M8	41	M8	41	9	
					11								
80	20	71	6,7	6,75	13,5	27	14,5	M8	41	M8	41	9	
105	20	94	9,7	9,25	17	34,2	15,7	M10	83	M12	140	13,4	
					16,5								
120	20	107	13,5	11,25	15	41,5	19	M12	140	M14	220	15,4	

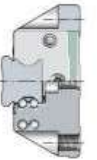

Four-row linear recirculating ball bearing and guideway assemblies

Full complement
H, S and SN carriages

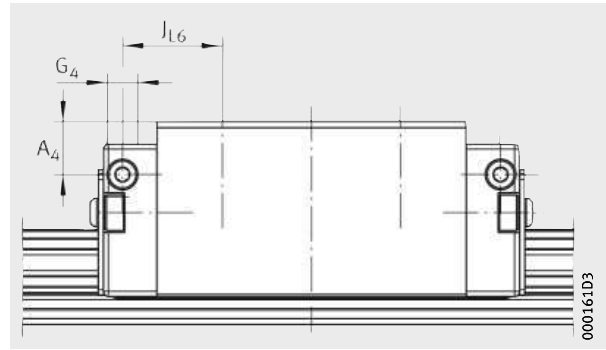

Lubrication connector on lateral face

Dimension table (continued) · Dimensions in mm

Designation	Carriage		Guideway		Lubrication connectors		
	Designation	Mass m ≈ kg	Designation	Mass m ≈ kg/m	A ₃	G ₃ ²⁾	
KUVE15-B-H	KWVE15-B-H	0,2	TKVD15-B ³⁾	1,44	8,3	M3	5,5
KUVE15-B-S	KWVE15-B-S	0,16			4,3		
KUVE20-B-H ⁴⁾	KWVE20-B-H	0,34	TKVD20	2,2	7,7	M5	7
KUVE20-B-S ⁴⁾	KWVE20-B-S	0,34			7,7		
KUVE20-B-SN	KWVE20-B-SN	0,29			4,7		
KUVE25-B-H	KWVE25-B-H	0,65	TKVD25	2,7	15	M6	7
KUVE25-B-S	KWVE25-B-S	0,56			11		
KUVE25-B-SN	KWVE25-B-SN	0,45			6		
KUVE30-B-H	KWVE30-B-H	1,04	TKVD30	4,3	14,5	M6	7
KUVE30-B-S	KWVE30-B-S	0,94			11,5		
KUVE30-B-SN	KWVE30-B-SN	0,8			7,5		
KUVE35-B-H	KWVE35-B-H	1,71	TKVD35	5,7	19,3	M6	7
KUVE35-B-S	KWVE35-B-S	1,3			12,3		
KUVE35-B-SN	KWVE35-B-SN	1,24			8,3		
KUVE45-B-H	KWVE45-B-H	3,36	TKVD45	9,2	26,5	M6	7
KUVE45-B-S	KWVE45-B-S	2,67			16,5		
KUVE45-B-SN	KWVE45-B-SN	2,12			8,5		
KUVE55-B-S	KWVE55-B-S	4,35	TKVD55-B	14	15	M6	7

¹⁾ Calculation of basic load ratings in accordance with DIN ISO 14728-1.

Based on practical experience, it may be possible to increase the basic dynamic load rating. The basic load rating can only be transmitted fully if the whole thread length is used and the adjacent construction is dimensioned appropriately.

²⁾ Maximum permissible screw depth for lubrication connectors.

³⁾ The new carriages cannot be used on the previous guideways TKVD15 or TKVD15-U.

⁴⁾ KUVE20-B-H and KUVE20-B-S are 100% identical in dimensions and performance. If a KUVE20-B-H is ordered, the order confirmation will contain the designation KUVE20-B-S.

⁵⁾ Lubrication connectors are included loose:

- S04 with KUVE20-B
- S05 with KUVE25-B to KUVE55-B
- S16 with KUVE15-B.

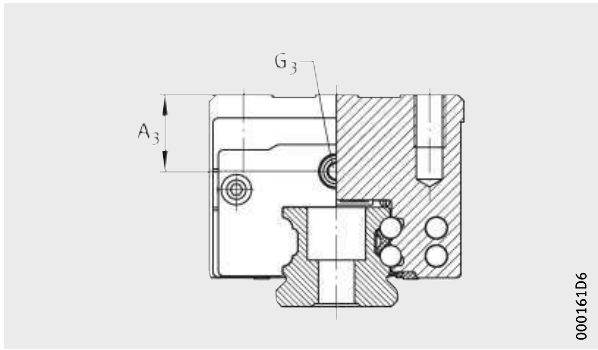

Lubrication connector on end face

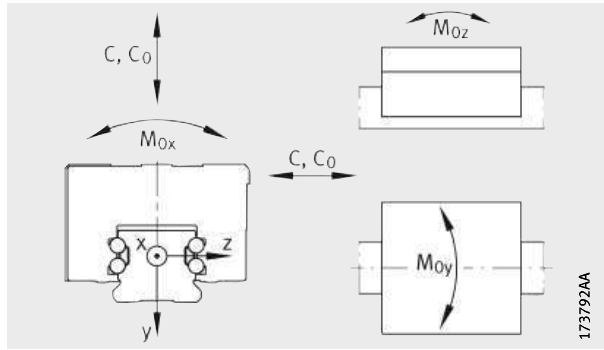

Load directions

			Load carrying capacity					
A ₄	G ₄	2)	J _{L6}	Basic load ratings ¹⁾		Moment ratings		
				dyn. C N	stat. C ₀ N	M _{0x} Nm	M _{0y} Nm	M _{0z} Nm
7,2 3,2	M3	5,5	11,1	7 200	14 500	150	100	100
4,6 4,6 3,3	M5 M3	5,5	11,4	13 100	27 000	332	240	240
10,5 6,5	M6	7	17,9	17 900	37 000	510	395	395
4	M3	6						
10 7 4,95	M6 M5	7	21,5	27 500	55 000	970	700	700
18 11 7	M6	7	22	38 000	72 000	1 465	1 020	1 020
26,5 16,5 8,5	M6	7	29,3	69 000	141 000	3 610	2 485	2 485
15	M6	7	40,5	104 000	213 000	5 600	2 730	2 730

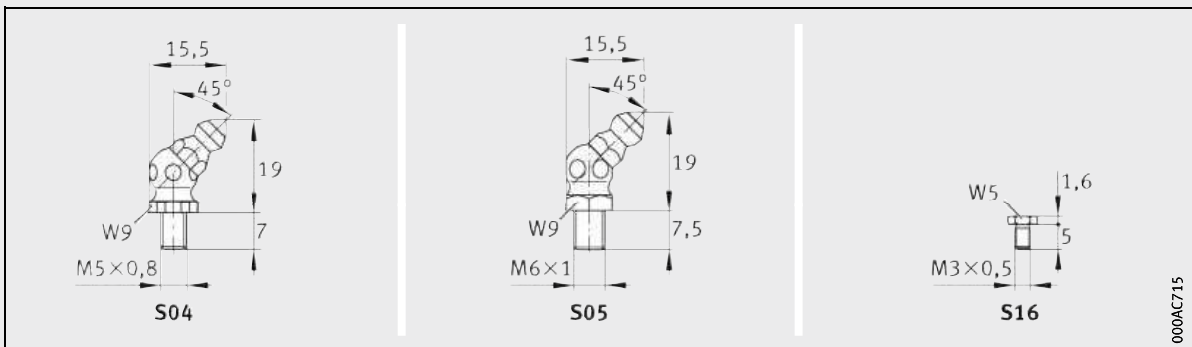
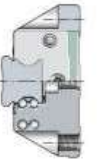

Lubrication connectors⁵⁾

Four-row linear recirculating ball bearing and guideway assemblies

Full complement
HL, SL and SNL carriages

Dimension table · Dimensions in mm											
Designation	Dimensions				Mounting dimensions						
	$l_{\max}^{2)}$	H	B	L	A ₁	J _B	b -0,005 -0,03	A ₂	L ₁	L _S	J _L
KUVE20-B-SL	5 880	30	44	88,9	12	32	20	6	67,9	1,3	50
KUVE20-B-SNL		27									
KUVE25-B-HL	5 880	40	48	109,1	12,5	35	23	6,5	86,5	1,65	50
KUVE25-B-SL		36									
KUVE25-B-SNL		31									
KUVE30-B-HL	5 860	45	60	127	16	40	28	10	100	1,65	60
KUVE30-B-SL		42									
KUVE30-B-SNL		38									
KUVE35-B-HL	5 860	55	70	145	18	50	34	10	113	1,65	72
KUVE35-B-SL		48									
KUVE35-B-SNL		44									
KUVE45-B-HL	5 835	70	86	172,7	20,5	60	45	13	134,6	2,2	80
KUVE45-B-SL		60									
KUVE45-B-SNL		52									
KUVE55-B-SL	5 820	70	100	211,6	23,5	75	53	12,5	170	2,2	95

For further table values, see page 322 and page 323.

① Locating face. ② Marking.

- 1) The stated torques represent maximum values for the secure transmission of forces in vibration-free, quasistatic applications ($S_0 = 1$). We recommend that the tightening torques for the screw connection of the adjacent construction should be determined at the customer under the conditions specific to the application and operation, observing the information in VDI Guideline 2230 Part 1 (2015) and the information in this description, see page 69 and page 26.
- 2) Maximum length of single-piece guideways.
Permissible number of guideway segments, see page 309.
- 3) a_L and a_R are dependent on the guideway length.

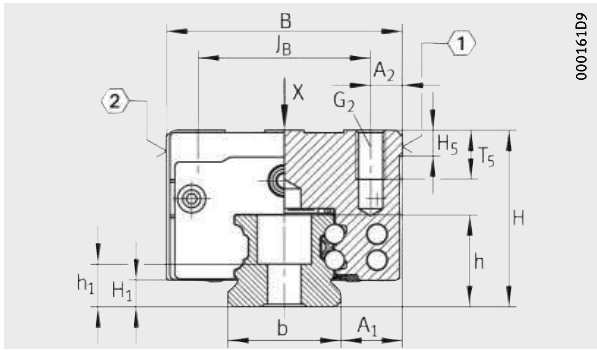

000161D9

KUVE...-B-HL, KUVE...-B-SL, KUVE...-B-SNL

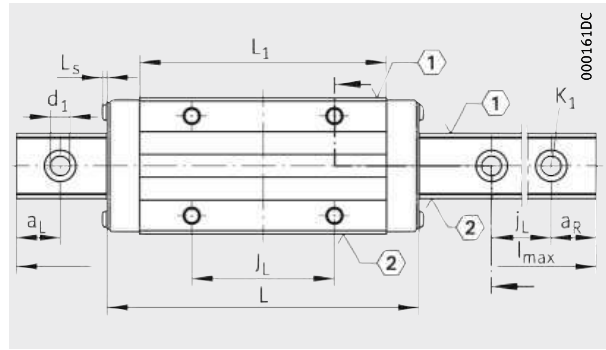

000161DC

KUVE...-B-HL, KUVE...-B-SL, KUVE...-B-SNL
View X rotated 90°

								Fixing screws ¹⁾				
j _L	a _L , a _R ³⁾		H ₁	H ₅	T ₅	h	h ₁	G ₂		K ₁		d ₁
	DIN ISO 4762-12.9							M _A Nm	M _A Nm			
	min.	max.										
60	20	53	4,5	5,25	7,5	17	8,6	M5	10	M5	10	5,8
60	20	53	5,1	5,25	10	18,7	8,2	M6	17	M6	17	6,8
					7,5							
80	20	71	5,9	6,25	13,5	23,5	11	M8	41	M8	41	9
					11							
80	20	71	6,7	6,75	13,5	27	14,5	M8	41	M8	41	9
105	20	94	9,7	9,25	17	34,2	15,7	M10	83	M12	140	13,4
					16,5							
120	20	107	13,5	11,25	15	41,5	19	M12	140	M14	220	15,4

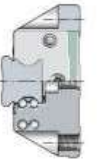

Four-row linear recirculating ball bearing and guideway assemblies

Full complement
HL, SL and SNL carriages

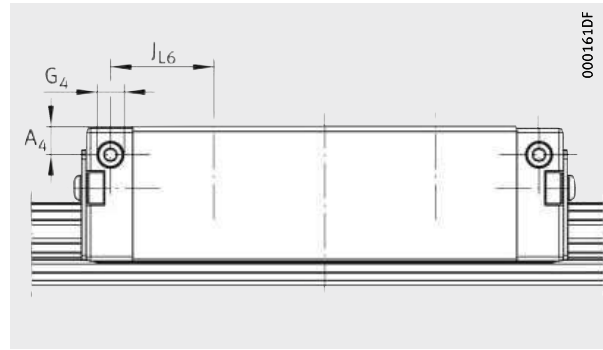

Lubrication connector on lateral face

Dimension table (continued) · Dimensions in mm

Designation	Carriage		Guideway		Lubrication connectors		
	Designation	Mass m ≈ kg	Designation	Mass m ≈ kg/m	A ₃	G ₃	2)
KUVE20-B-SL	KWVE20-B-SL	0,46	TKVD20	2,2	7,7	M5	7
KUVE20-B-SNL	KWVE20-B-SNL	0,38			4,7		
KUVE25-B-HL	KWVE25-B-HL	1	TKVD25	2,7	15	M6	7
KUVE25-B-SL	KWVE25-B-SL	1			11		
KUVE25-B-SNL	KWVE25-B-SNL	0,62			6		
KUVE30-B-HL	KWVE30-B-HL	1,43	TKVD30	4,3	14,5	M6	7
KUVE30-B-SL	KWVE30-B-SL	1,7			11,5		
KUVE30-B-SNL	KWVE30-B-SNL	1,1			7,5		
KUVE35-B-HL	KWVE35-B-HL	2,4	TKVD35	5,7	19,3	M6	7
KUVE35-B-SL	KWVE35-B-SL	1,81			12,3		
KUVE35-B-SNL	KWVE35-B-SNL	1,72			8,3		
KUVE45-B-HL	KWVE45-B-HL	4,27	TKVD45	9,2	26,5	M6	7
KUVE45-B-SL	KWVE45-B-SL	3,38			16,5		
KUVE45-B-SNL	KWVE45-B-SNL	2,68			8,5		
KUVE55-B-SL	KWVE55-B-SL	6,3	TKVD55-B	14	15	M6	7

1) Calculation of basic load ratings in accordance with DIN ISO 14728-1.

Based on practical experience, it may be possible to increase the basic dynamic load rating. The basic load rating can only be transmitted fully if the whole thread length is used and the adjacent construction is dimensioned appropriately.

2) Maximum permissible screw depth for lubrication connectors.

3) Lubrication connectors are included loose:

- S04 with KUVE20-B
- S05 with KUVE25-B to KUVE55-B
- S16 with KUVE15-B.

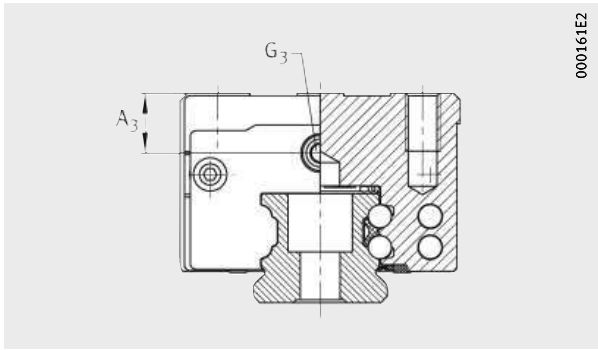

Lubrication connector on end face

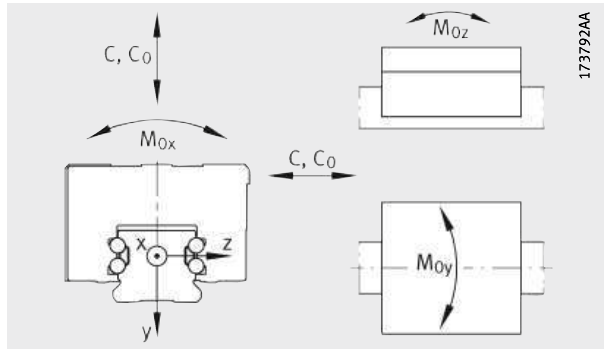

Load directions

			Load carrying capacity					
A ₄	G ₄	2)	J _{L6}	Basic load ratings ¹⁾		Moment ratings		
				dyn. C N	stat. C ₀ N	M _{0x} Nm	M _{0y} Nm	M _{0z} Nm
4,6	M5	5,5	13,2	16 200	36 500	452	430	430
3,3	M3							
10,5	M6	7	23,3	23 400	54 000	745	825	825
6,5								
4	M3	6	22,5					
10	M6	7	25,5	34 500	74 000	1 310	1 240	1 240
7								
4,95	M5		25,1					
18	M6	7	27,5	47 500	100 000	2 625	1 890	1 890
11								
7								
26,5	M6	7	35,3	82 000	181 000	4 635	4 000	4 000
16,5								
8,5								
15	M6	7	49,5	127 000	285 000	7 500	4 725	4 800

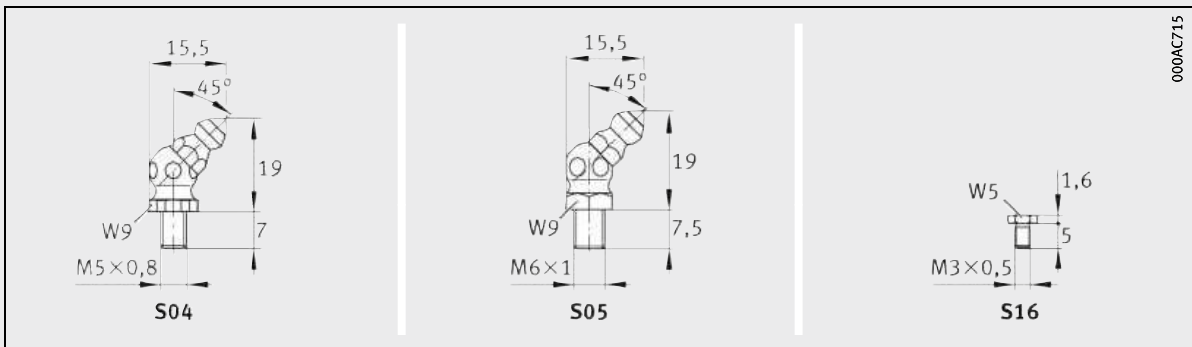
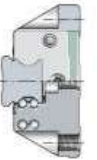

Lubrication connectors³⁾

Four-row linear recirculating ball bearing and guideway assemblies

Full complement

E carriages

Without screw threads

Dimension table · Dimensions in mm											
Designation	Dimensions				Mounting dimensions						
	$l_{\max}^{2)}$	H	B	L	A_1	J_B	b -0,005 -0,03	A_2	L_1	L_S	J_L
KUVE15-B-E	2 880	24	52	61,2	18,5	41	15	5,5	39,8	1,3	26
KUVE20-B-E	5 880	28	59	71,4	19,5	49	20	5	50,4	1,3	32
KUVE25-B-E	5 880	33	73	83,3	25	60	23	6,5	60,7	1,65	35
KUVE30-B-E	5 860	42	90	99	31	72	28	9	72	1,65	40
KUVE35-B-E	5 860	48	100	112	33	82	34	9	80	1,65	50

For further table values, see page 326 and page 327.

① Locating face. ② Marking. ③ No thread.

1) The stated torques represent maximum values for the secure transmission of forces in vibration-free, quasistatic applications ($S_0 = 1$). We recommend that the tightening torques for the screw connection of the adjacent construction should be determined at the customer under the conditions specific to the application and operation, observing the information in VDI Guideline 2230 Part 1 (2015) and the information in this description, see page 69 and page 26.

2) Maximum length of single-piece guideways.
Permissible number of guideway segments, see page 309.

3) a_L and a_R are dependent on the guideway length.

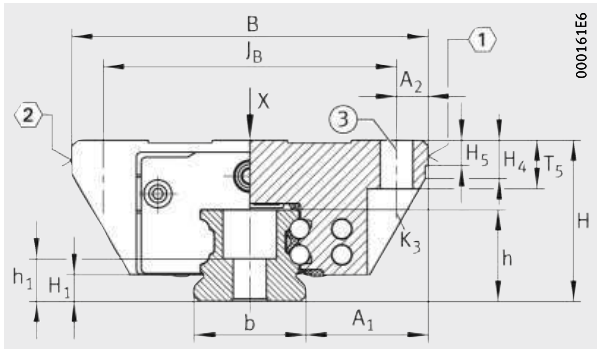

KUVE...-B-E

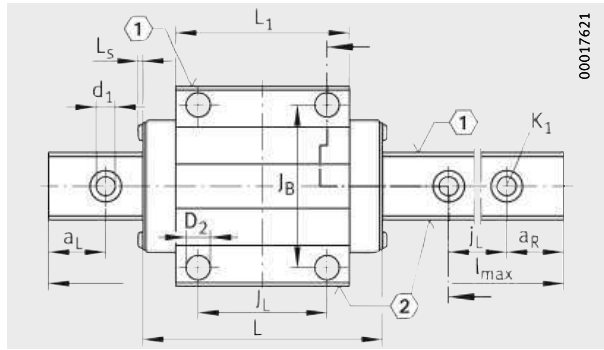

KUVE...-B-E
View X rotated 90°

									Fixing screws ¹⁾					
j _L	a _L , a _R ³⁾		H ₁	H ₄	H ₅	T ₅	h	h ₁	K ₁		K ₃		d ₁	D ₂
	DIN ISO 4762-12.9													
	min.	max.							M _A Nm		M _A Nm			
60	20	53	4,3	6,1	4,75	7	15	8,15	M4	5	M4	5	4,6	4,5
60	20	53	4,5	11,2	5,25	9	17	9,1	M5	10	M5	10	5,8	5,5
60	20	53	5,1	7,85	5,25	10	18,7	8,7	M6	17	M6	17	6,8	6,7
80	20	71	5,9	13,8	6,25	12	23,5	11,5	M8	41	M8	41	9	8,6
80	20	71	6,7	14,3	6,75	13	27	15	M8	41	M8	41	9	8,6

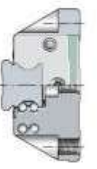

Four-row linear recirculating ball bearing and guideway assemblies

Full complement

E carriages

Without screw threads

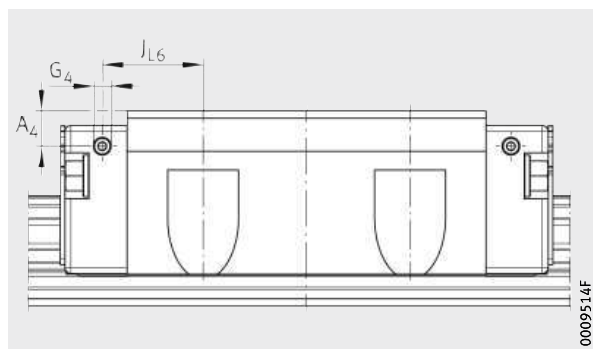

Lubrication connector on lateral face

Dimension table (continued) · Dimensions in mm

Designation	Carriage		Guideway		Lubrication connectors		
	Designation	Mass m ≈ kg	Designation	Mass m ≈ kg/m	A ₃	G ₃ 2)	
KUVE15-B-E	KWVE15-B-E	0,2	TKVD15-B	1,44	4,3	M3	5,5
KUVE20-B-E	KWVE20-B-E	0,36	TKVD20	2,2	6	M5	7
KUVE25-B-E	KWVE25-B-E	0,68	TKVD25	2,7	8	M6	7
KUVE30-B-E	KWVE30-B-E	1,2	TKVD30	4,3	11,5	M6	7
KUVE35-B-E	KWVE35-B-E	1,75	TKVD35	5,7	12,3	M6	7

1) Calculation of basic load ratings in accordance with DIN ISO 14728-1.

Based on practical experience, it may be possible to increase the basic dynamic load rating. The basic load rating can only be transmitted fully if the whole thread length is used and the adjacent construction is dimensioned appropriately.

2) Maximum permissible screw depth for lubrication connectors.

3) Lubrication connectors are included loose:

- S04 with KUVE20-B
- S05 with KUVE25-B to KUVE55-B
- S16 with KUVE15-B.

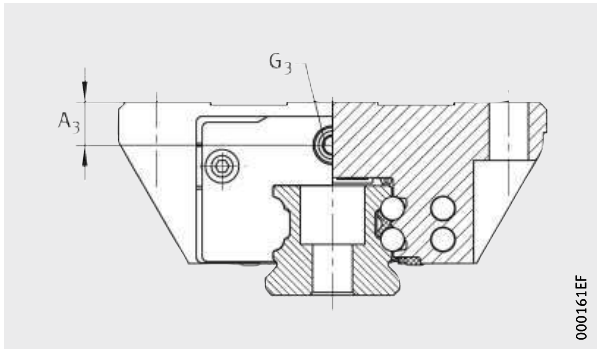

Lubrication connector on end face

000161EF

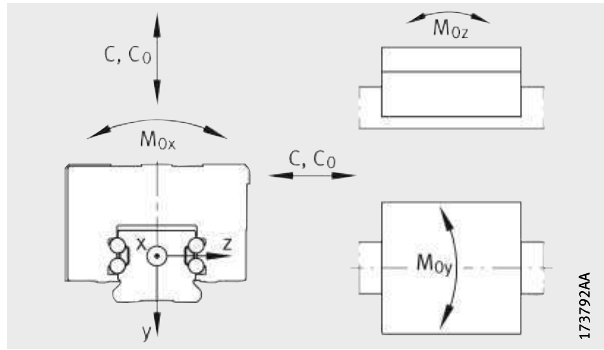

Load directions

173792AA

				Load carrying capacity				
A ₄	G ₄		J _{L6}	Basic load ratings ¹⁾		Moment ratings		
		2)		dyn. C N	stat. C ₀ N	M _{0x} Nm	M _{0y} Nm	M _{0z} Nm
3,2	M3	5,5	11,1	7 200	14 500	150	100	100
4,3	M3	5,5	13,4	13 100	27 000	332	240	240
6	M3	7	17,05	17 900	37 000	510	395	395
7	M6	7	21,1	27 500	55 000	970	700	700
11	M6	7	22	38 000	72 500	1 465	1 020	1 020

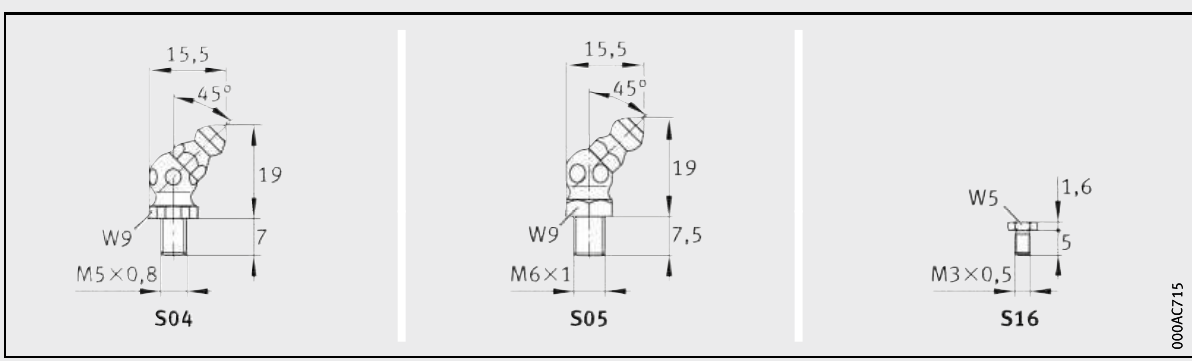
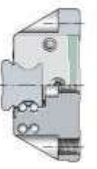

Lubrication connectors³⁾

000AC715

Four-row linear recirculating ball bearing and guideway assemblies

Full complement ES carriages

Dimension table · Dimensions in mm

Designation ¹⁾	Dimensions				Mounting dimensions					
	$l_{\max}^{3)}$	H	B	L	A_1	J_B	b -0,06 -0,03	A_2	L_1	L_S
KUVE15-B-ES	2 880	24	34	61,2	9,5	26	15	4	39,8	1,3
KUVE20-B-ES	5 880	28	42	71,4	11	32	20	5	50,4	1,3
KUVE25-B-ES	5 880	33	48	83,3	12,5	35	23	6,5	60,7	1,65
KUVE30-B-ES	5 860	42	60	99	16	40	28	10	72	1,65
KUVE35-B-ES	5 860	48	70	112	18	50	34	10	80	1,65

For further table values, see page 330 and page 331.

① Locating face. ② Marking.

- 1) KUVE15-B-ES and KUVE15-B-S, KUVE30-B-ES and KUVE30-B-S as well as KUVE35-B-ES and KUVE35-B-S are in each case 100% identical in dimensions and performance.
If a KUVE15-B-ES, KUVE30-B-ES or KUVE35-B-ES is ordered, the confirmation of the quotation will contain the designation KUVE15-B-S, KUVE30-B-S or KUVE35-B-S.
- 2) The stated torques represent maximum values for the secure transmission of forces in vibration-free, quasistatic applications ($S_0 = 1$). We recommend that the tightening torques for the screw connection of the adjacent construction should be determined at the customer under the conditions specific to the application and operation, observing the information in VDI Guideline 2230 Part 1 (2015) and the information in this description, see page 69 and page 26.
- 3) Maximum length of single-piece guideways.
Permissible number of guideway segments, see page 309.
- 4) a_L and a_R are dependent on the guideway length.

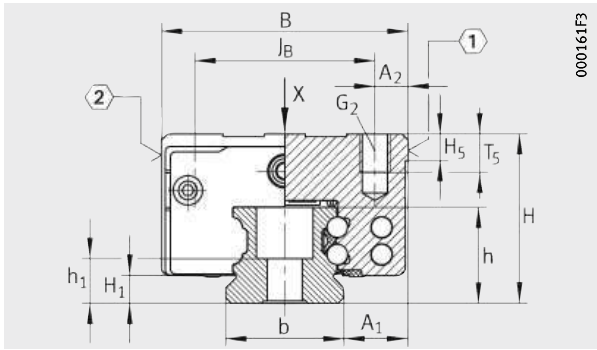

KUVE...-B-ES

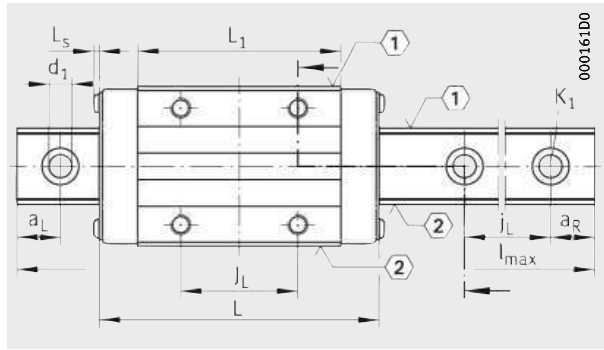

KUVE...-B-ES
View X rotated 90°

									Fixing screws ²⁾				
J _L	j _L	a _L , a _R ⁴⁾		H ₁	H ₅	T ₅	h	h ₁	G ₂		K ₁		d ₁
									DIN ISO 4762-12.9				
		min.	max.						M _A Nm		M _A Nm		
26	60	20	53	4,3	4,75	6	15	7,6	M4	5	M4	5	4,6
32	60	20	53	4,5	5,25	7,5	17	8,6	M5	10	M5	10	5,8
35	60	20	53	5,2	5,25	10	18,7	8,2	M6	17	M6	17	6,8
40	80	20	71	5,9	6,25	13,5	23,5	11	M8	41	M8	41	9
50	80	20	71	6,7	6,75	13,5	27	14,5	M8	41	M8	41	9

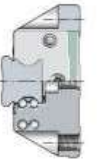

Four-row linear recirculating ball bearing and guideway assemblies

Full complement ES carriages

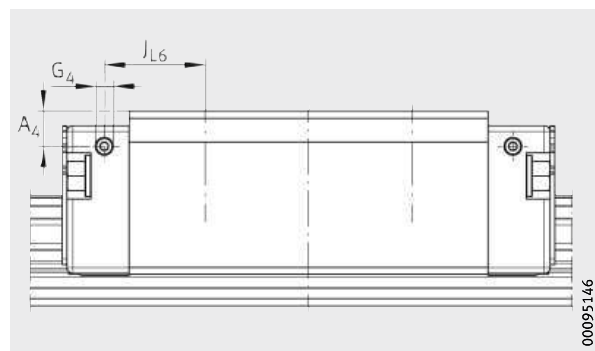

Lubrication connector on lateral face

Dimension table (continued) · Dimensions in mm

Designation	Carriage		Guideway		Lubrication connectors		
	Designation	Mass m ≈ kg	Designation	Mass m ≈ kg/m	A ₃	G ₃ 2)	
KUVE15-B-ES	KWVE15-B-ES	0,16	TKVD15-B ³⁾	1,44	4,3	M3	5,5
KUVE20-B-ES	KWVE20-B-ES	0,31	TKVD20	2,2	8	M5	7
KUVE25-B-ES	KWVE25-B-ES	0,56	TKVD25	2,7	11	M6	7
KUVE30-B-ES	KWVE30-B-ES	0,94	TKVD30	4,3	11,5	M6	7
KUVE35-B-ES	KWVE35-B-ES	1,3	TKVD35	5,7	12,3	M6	7

¹⁾ Calculation of basic load ratings in accordance with DIN ISO 14728-1.

Based on practical experience, it may be possible to increase the basic dynamic load rating. The basic load rating can only be transmitted fully if the whole thread length is used and the adjacent construction is dimensioned appropriately.

²⁾ Maximum permissible screw depth for lubrication connectors.

³⁾ The new carriages cannot be used on the existing guideways TKVD15 or TKVD15-U.

⁴⁾ Lubrication connectors are included loose:

- S04 with KUVE20-B
- S05 with KUVE25-B to KUVE55-B
- S16 with KUVE15-B.

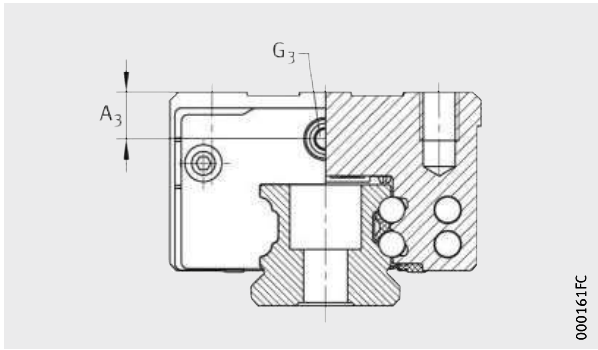

Lubrication connector on end face

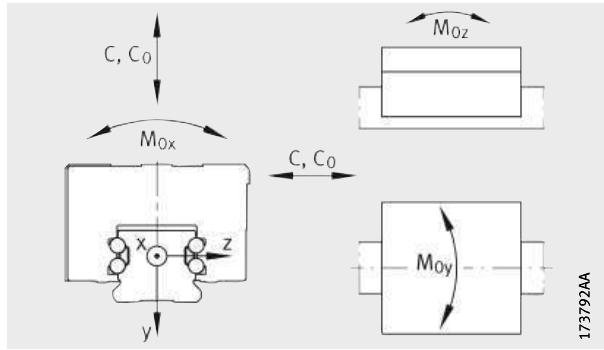

Load directions

				Load carrying capacity				
A ₄	G ₄		J _{L6}	Basic load ratings ¹⁾		Moment ratings		
		2)		dyn. C N	stat. C ₀ N	M _{0x} Nm	M _{0y} Nm	M _{0z} Nm
3,2	M3	5,5	9,1	7 200	14 500	150	100	100
4,6	M3	5,5	9,4	13 100	27 000	332	240	240
6,5	M3	7	12,85	17 900	37 000	510	395	395
7	M6	7	15,5	27 500	55 000	970	700	700
11	M6	7	16	38 000	72 500	1 465	1 020	1 020

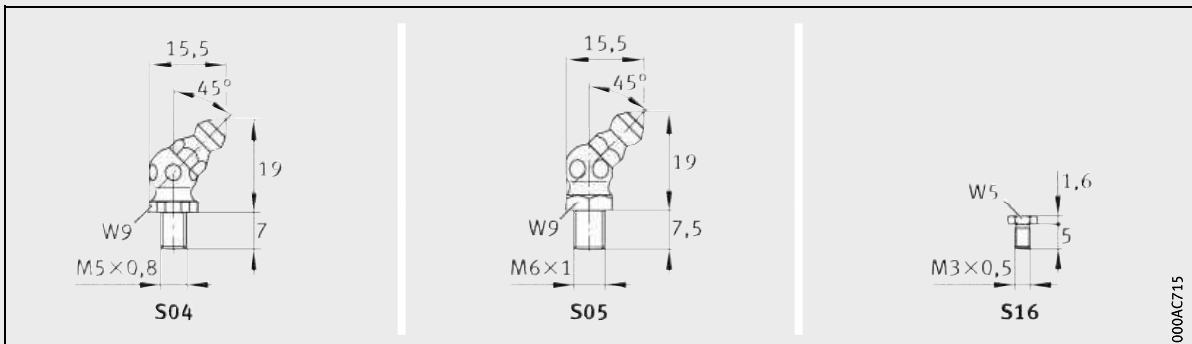
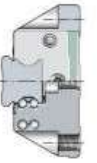

Lubrication connectors⁴⁾

Four-row linear recirculating ball bearing and guideway assemblies

Full complement

EC carriages

Without screw threads

Dimension table · Dimensions in mm										
Designation	Dimensions				Mounting dimensions					
	$l_{\max}^{2)}$	H	B	L	A_1	J_B	b -0,005 -0,03	A_2	L_1	L_s
KUVE15-B-EC	2 880	24	52	44,5	18,5	41	15	5,5	23,1	1,3
KUVE20-B-EC	5 880	28	59	50,4	19,5	49	20	5	29,4	1,65
KUVE25-B-EC	5 880	33	73	58,2	25	60	23	6,5	35,6	1,65
KUVE30-B-EC	5 860	42	90	69	31	72	28	9	42	1,65
KUVE35-B-EC	5 860	48	100	76,2	33	82	34	9	44,2	1,65
KUVE45-B-EC	5 835	60	120	97,8	37,5	100	45	10	59,7	2,2

For further table values, see page 334 and page 335.

① Locating face. ② Marking. ③ No thread.

1) The stated torques represent maximum values for the secure transmission of forces in vibration-free, quasistatic applications ($S_0 = 1$). We recommend that the tightening torques for the screw connection of the adjacent construction should be determined at the customer under the conditions specific to the application and operation, observing the information in VDI Guideline 2230 Part 1 (2015) and the information in this description, see page 69 and page 26.

2) Maximum length of single-piece guideways.
Permissible number of guideway segments, see page 309.

3) a_L and a_R are dependent on the guideway length.

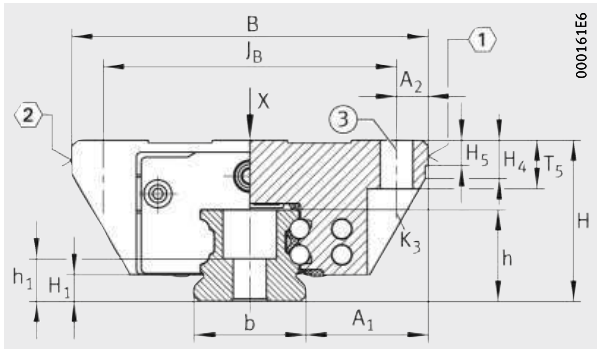

KUV...-B-EC

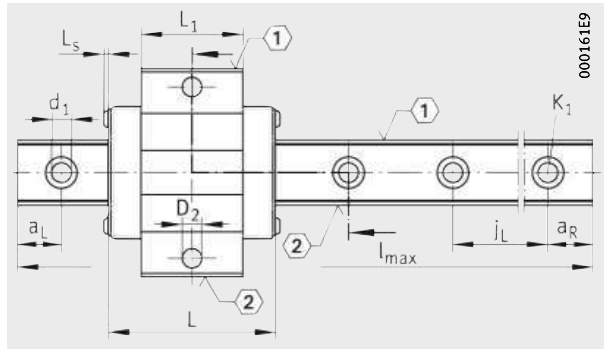

KUV...-B-EC
View X rotated 90°

j _L	a _L , a _R ³⁾		H ₁	H ₄	H ₅	T ₅	h	h ₁	Fixing screws ¹⁾					
									DIN ISO 4 762-12.9		d ₁	D ₂		
									K ₁	M _A Nm			K ₃	M _A Nm
min.	max.													
60	20	53	4,3	6,1	4,75	7	15	7,6	M4	5	M4	5	4,6	4,5
60	20	53	4,5	11,2	5,25	9	17	8,6	M5	10	M5	10	5,8	5,5
60	20	53	5,1	7,85	5,25	10	18,7	8,2	M6	17	M6	17	6,8	6,7
80	20	71	5,9	13,8	6,25	12	23,5	11	M8	41	M8	41	9	8,6
80	20	71	6,7	14,3	6,75	13,5	27	14,5	M8	41	M8	41	9	8,6
105	20	94	9,7	19,9	9,25	15	34,2	15,7	M12	140	M10	83	13,4	10,6

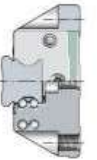

Four-row linear recirculating ball bearing and guideway assemblies

Full complement
EC carriages
Without screw threads

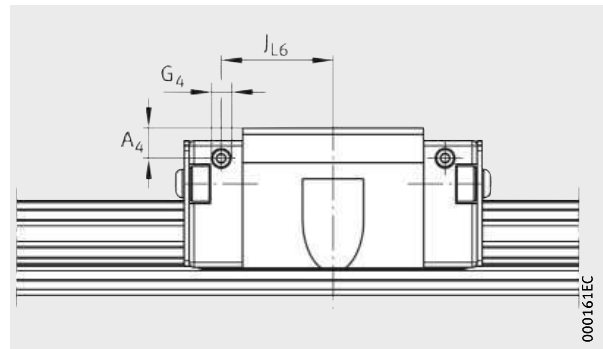

Lubrication connector on lateral face

Dimension table (continued) · Dimensions in mm

Designation	Carriage		Guideway		Lubrication connectors		
	Designation	Mass m ≈ kg	Designation	Mass m ≈ kg/m	A ₃	G ₃	²⁾
KUVE15-B-EC	KWVE15-B-EC	0,13	TKVD15-B ³⁾	1,44	4,3	M3	5,5
KUVE20-B-EC	KWVE20-B-EC	0,23	TKVD20	2,2	6	M5	7
KUVE25-B-EC	KWVE25-B-EC	0,4	TKVD25	2,7	8	M6	7
KUVE30-B-EC	KWVE30-B-EC	0,75	TKVD30	4,3	11,5	M6	7
KUVE35-B-EC	KWVE35-B-EC	1,04	TKVD35	5,7	12,3	M6	7
KUVE45-B-EC	KWVE45-B-EC	2,07	TKVD45	9,2	16,5	M6	7

¹⁾ Calculation of basic load ratings in accordance with DIN ISO 14728-1.

Based on practical experience, it may be possible to increase the basic dynamic load rating. The basic load rating can only be transmitted fully if the whole thread length is used and the adjacent construction is dimensioned appropriately.

²⁾ Maximum permissible screw depth for lubrication connectors.

³⁾ The new carriages cannot be used on the previous guideways TKVD15 or TKVD15-U.

⁴⁾ Lubrication connectors are included loose:

- S04 with KUVE20-B
- S05 with KUVE25-B to KUVE55-B
- S16 with KUVE15-B.

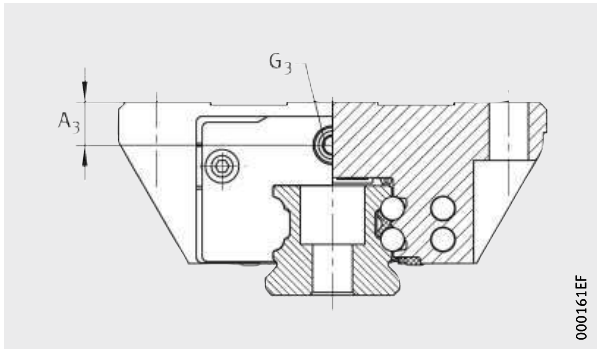

Lubrication connector on end face

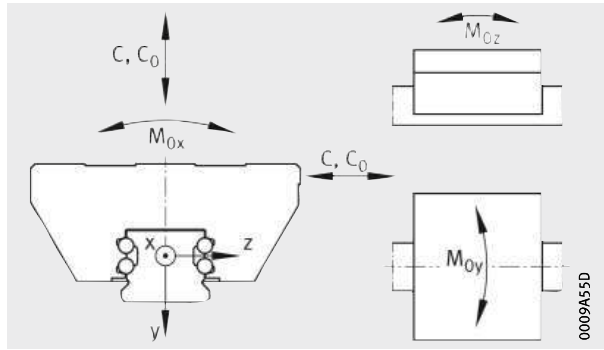

Load directions

			Load carrying capacity					
A ₄	G ₄	2)	J _{L6}	Basic load ratings ¹⁾		Moment ratings		
				dyn. C N	stat. C ₀ N	M _{0x} Nm	M _{0y} Nm	M _{0z} Nm
3,2	M3	5,5	15,8	4 900	8 300	86	35	35
4,3	M3	5,5	18,9	8 900	15 400	190	85	85
6	M3	6	22	12 500	22 200	305	155	155
7	M6	7	26,5	18 700	31 500	554	248	248
11	M6	7	29,1	24 600	39 000	790	330	330
16,5	M6	7	37,9	46 500	80 000	2 060	883	883

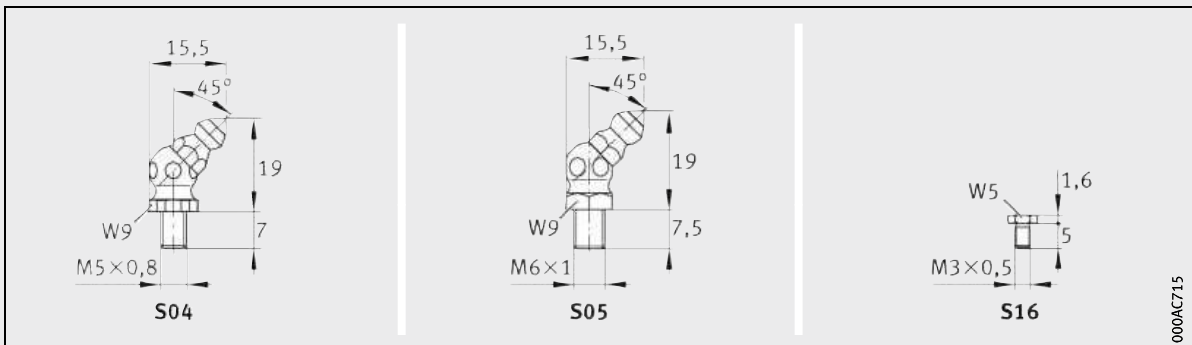
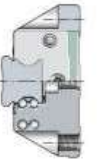

Lubrication connectors⁴⁾

Four-row linear recirculating ball bearing and guideway assemblies

Full complement
ESC carriages

Dimension table · Dimensions in mm										
Designation	Dimensions				Mounting dimensions					
	$l_{\max}^{2)}$	H	B	L	A_1	J_B	b -0,005 -0,03	A_2	L_1	L_5
KUVE15-B-ESC	2 880	24	34	44,5	9,5	26	15	4	23,1	1,3
KUVE20-B-ESC	5 880	28	42	50,4	11	32	20	5	29,4	1,65
KUVE25-B-ESC	5 880	33	48	58,2	12,5	35	23	6,5	35,6	1,65
KUVE30-B-ESC	5 860	42	60	69	16	40	28	10	42	1,65
KUVE35-B-ESC	5 860	48	70	76,2	18	50	34	10	44,2	1,65
KUVE45-B-ESC	5 835	60	86	97,8	20,5	60	45	13	59,7	2,2

For further table values, see page 338 and page 339.

① Locating face. ② Marking.

- 1) The stated torques represent maximum values for the secure transmission of forces in vibration-free, quasistatic applications ($S_0 = 1$). We recommend that the tightening torques for the screw connection of the adjacent construction should be determined at the customer under the conditions specific to the application and operation, observing the information in VDI Guideline 2230 Part 1 (2015) and the information in this description, see page 69 and page 26.
- 2) Maximum length of single-piece guideways.
Permissible number of guideway segments, see page 309.
- 3) a_L and a_R are dependent on the guideway length.

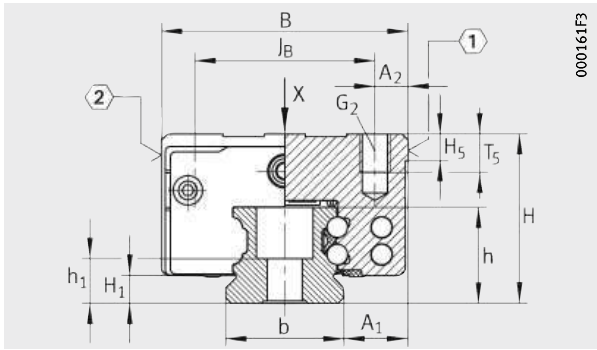

KUVE..-B-ESC

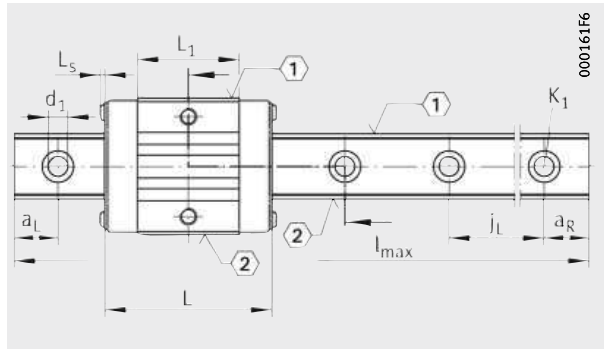

KUVE..-B-ESC
View X rotated 90°

								Fixing screws ¹⁾				
j _L	a _L , a _R ³⁾		H ₁	H ₅	T ₅	h	h ₁	G ₂		K ₁		d ₁
								DIN ISO 4762-12.9				
	min.	max.						M _A Nm		M _A Nm		
60	20	53	4,3	4,75	6	15	7,6	M4	5	M4	5	4,6
60	20	53	4,5	5,25	7,5	17	8,6	M5	10	M5	10	5,8
60	20	53	5,1	5,25	10	18,7	8,2	M6	17	M6	17	6,8
80	20	71	5,9	6,25	13,5	23,5	11	M8	41	M8	41	9
80	20	71	6,7	6,75	13,5	27	14,5	M8	41	M8	41	9
105	20	94	9,7	9,25	17	34,2	15,7	M10	83	M12	140	13,4

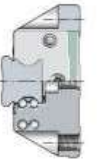

Four-row linear recirculating ball bearing and guideway assemblies

Full complement ESC carriages

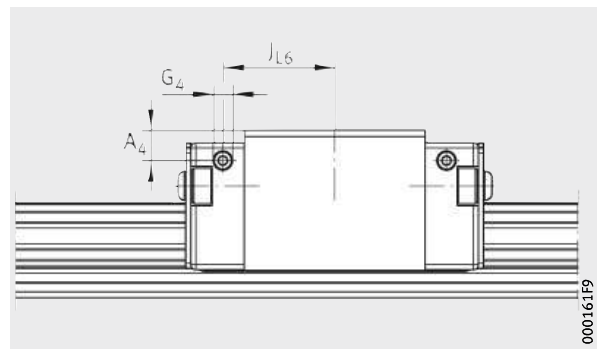

Lubrication connector on lateral face

Dimension table (continued) · Dimensions in mm

Designation	Carriage		Guideway		Lubrication connectors		
	Designation	Mass m ≈ kg	Designation	Mass m ≈ kg/m	A ₃	G ₃	2)
KUVE15-B-ESC	KWVE15-B-ESC	0,12	TKVD15-B ³⁾	1,44	4,3	M3	5,5
KUVE20-B-ESC	KWVE20-B-ESC	0,18	TKVD20	2,2	6	M5	7
KUVE25-B-ESC	KWVE25-B-ESC	0,3	TKVD25	2,7	8	M6	7
KUVE30-B-ESC	KWVE30-B-ESC	0,57	TKVD30	4,3	11,5	M6	7
KUVE35-B-ESC	KWVE35-B-ESC	1,04	TKVD35	5,7	12,3	M6	7
KUVE45-B-ESC	KWVE45-B-ESC	1,8	TKVD45	9,2	16,5	M6	7

1) Calculation of basic load ratings in accordance with DIN ISO 14728-1.

Based on practical experience, it may be possible to increase the basic dynamic load rating. The basic load rating can only be transmitted fully if the whole thread length is used and the adjacent construction is dimensioned appropriately.

2) Maximum permissible screw depth for lubrication connectors.

3) The new carriages cannot be used on the previous guideways TKVD15 or TKVD15-U.

4) Lubrication connectors are included loose:

- S04 with KUVE20-B
- S05 with KUVE25-B to KUVE55-B
- S16 with KUVE15-B.

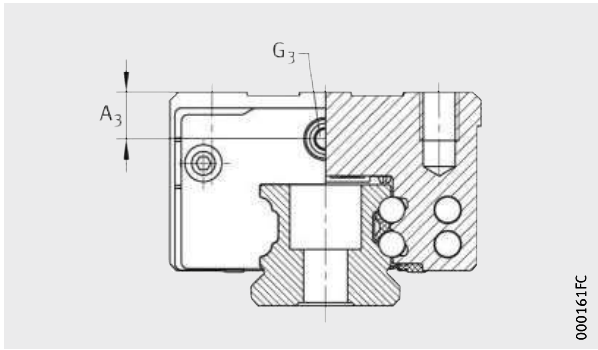

Lubrication connector on end face

000161FC

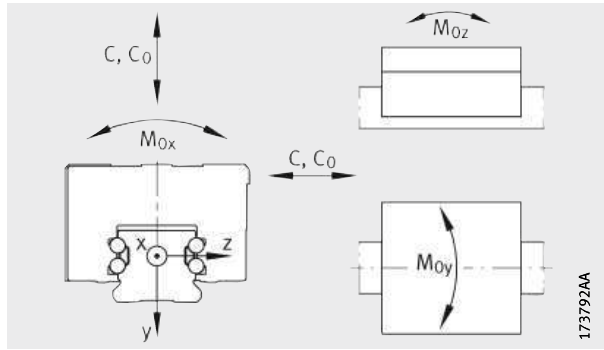

Load directions

173792AA

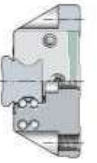

				Load carrying capacity				
A ₄	G ₄		J _{L6}	Basic load ratings ¹⁾		Moment ratings		
		2)		dyn. C N	stat. C ₀ N	M _{0x} Nm	M _{0y} Nm	M _{0z} Nm
3,2	M3	5,5	15,8	4 900	8 300	86	35	35
4,3	M3	5,5	18,9	8 900	15 400	190	85	85
6	M3	6	22	12 500	22 200	305	155	155
7	M6	7	26,5	18 700	31 500	554	248	248
11	M6	7	29,1	24 600	39 000	790	330	330
16,5	M6	7	37,9	46 500	80 000	2 060	883	883

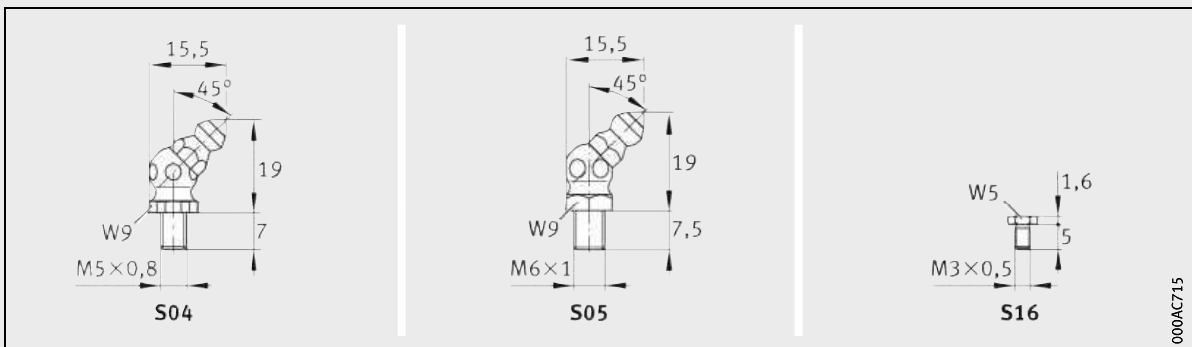

Lubrication connectors⁴⁾

000AC715

Four-row linear recirculating ball bearing and guideway assemblies

Full complement
Wide guideway
W and WL carriages

Dimension table · Dimensions in mm															
Designation	Dimensions				Mounting dimensions										
	$l_{\max}^{2)}$	H	B	L	A_1	J_B	j_B	a_5	b	A_2	L_1	J_L	j_L	$a_L, a_R^{3)}$	
														min.	max.
KUVE15-W	2 890	21	68	55,6	15,5	60	22	7,5	37	4	39,8	29	50	20	44
KUVE20-W	2 880	27	80	69,8	19	70	24	9	42	5	50,4	40	60	20	53
KUVE20-WL				87,3							67,9				
KUVE25-W	5 860	35	120	81,7	25,5	107	40	14,5	69	6,5	60,7	45	80	20	71
KUVE25-WL				107,5							86,5	60			
KUVE30-W	5 860	42	142	97,5	31	124	50	15	80	9	72	52	80	20	71
KUVE35-WL	5 860	50	162	140,2	36	144	60	15	90	9	109,8	80	80	20	71

Further table values, see page 342 and page 343.

① Locating face. ② Marking.

- 1) The stated torques represent maximum values for the secure transmission of forces in vibration-free, quasistatic applications ($S_0 = 1$). We recommend that the tightening torques for the screw connection of the adjacent construction should be determined at the customer under the conditions specific to the application and operation, observing the information in VDI Guideline 2230 Part 1 (2015) and the information in this description, see page 69 and page 26.
- 2) Maximum length of single-piece guideways.
Permissible number of guideway segments, see page 309.
- 3) a_L and a_R are dependent on the guideway length.
- 4) For location from above:
The maximum screw depth for the two central threaded holes is $T_6 + 2,5$ mm.

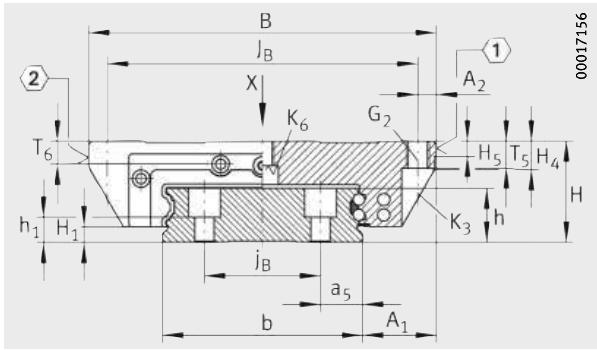

KUVE...-W, KUVE...-WL

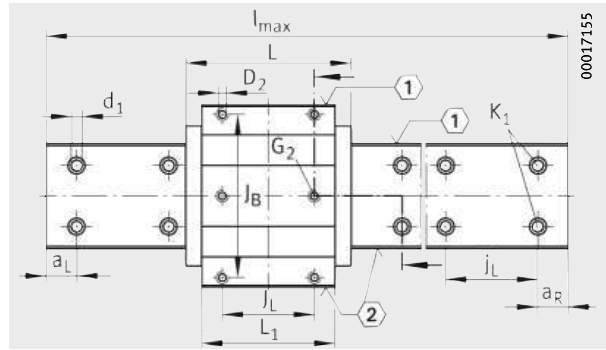

KUVE...-W, KUVE...-WL
View X rotated 90°

							Fixing screws ¹⁾												
H ₁	H ₅	H ₄	T ₅	T ₆ ⁴⁾	h	h ₁	DIN ISO 4762-12.9				DIN 7984-8.8				d ₁	D ₂			
							G ₂	K ₁	K ₃	K ₆	K ₆		K ₆						
							M _A Nm	M _A Nm	M _A Nm	M _A Nm	M _A Nm	M _A Nm	M _A Nm	M _A Nm					
2,1	4,5	7,7	7	4,8	12,9	6	M5	5,8	M4	5	M4	5	-	-	M4	2	4,6	4,5	
4,6	5	10,6	10	6	17	10	M6	10	M4	5	M5	10	-	-	M5	4	5,8	5,5	
				6									M6	17	-	-			
5,2	5	9,9	10	8,5	18,7	8,2	M8	41	M6	17	M6	17	-	-	M6	8	6,8	6,7	
				10									M6	17	-	-			
6	6	13,8	12	12	23,5	11	M10	41	M8	41	M8	41	-	-	M8	12	9	8,6	
6,8	6,5	16,3	13	13	27	14,5	M10	41	M8	41	M8	41	M8	41	-	-	9	8,6	

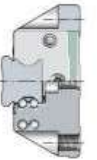

Four-row linear recirculating ball bearing and guideway assemblies

Full complement
Wide guideway
W and WL carriages

Dimension table (continued) · Dimensions in mm

Designation	Carriage		Guideway	
	Designation	Mass m ≈ kg	Designation	Mass m ≈ kg/m
KUVE15-W	KWVE15-W	0,27	TKVD15-W	3,6
KUVE20-W	KWVE20-W	0,5	TKVD20-W	5
KUVE20-WL	KWVE20-WL	0,7		
KUVE25-W	KWVE25-W	1,1	TKVD25-W	9,4
KUVE25-WL	KWVE25-WL	1,46		
KUVE30-W	KWVE30-W	1,95	TKVD30-W	13,6
KUVE35-WL	KWVE35-WL	4,11	TKVD35-W	17,4

- 1) Calculation of basic load ratings in accordance with DIN ISO 14728-1.
Based on practical experience, it may be possible to increase the basic dynamic load rating.
The basic load rating can only be transmitted fully if the full thread length is used and the adjacent construction is dimensioned accordingly.
- 2) Maximum permissible screw depth for lubrication connectors.
- 3) Lubrication connectors are included loose:
 - S04 with KUVE20-W
 - S05 with KUVE25-W to KUVE35-WL
 - S16 with KUVE15-W.

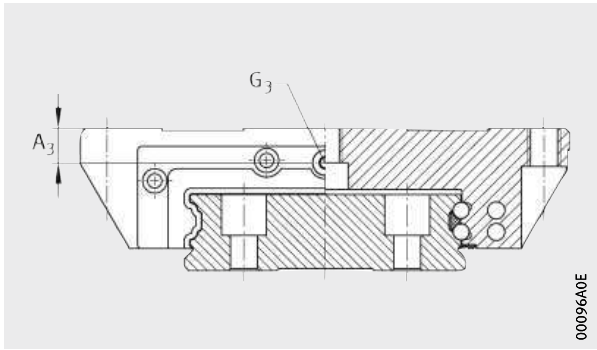

Lubrication connector on end face

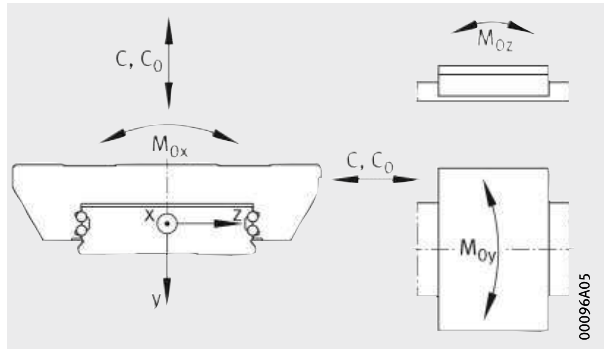

Load directions

Lubrication connectors			Load carrying capacity				
A ₃	G ₃	2)	Basic load ratings ¹⁾		Moment ratings		
			dyn. C N	stat. C ₀ N	M _{0x} Nm	M _{0y} Nm	M _{0z} Nm
3,6	M3	4	7 200	14 500	332	100	100
5	M6	5	13 100	27 000	687	240	240
			16 200	36 500	920	400	400
10	M6	6	17 900	37 000	1 470	395	395
			23 400	54 000	2 225	825	825
11,25	M6	6	27 500	55 000	2 660	700	700
14,3	M6	6	47 500	100 000	5 550	1 890	1 890

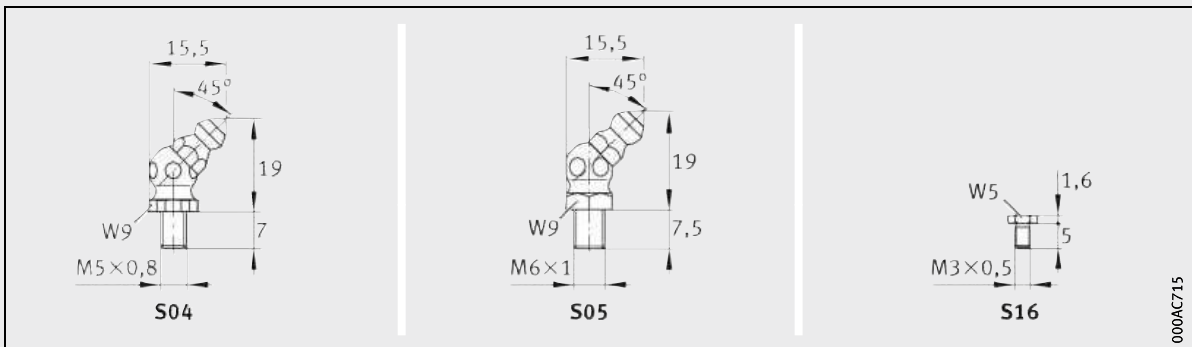
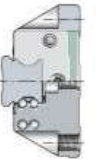

Lubrication connectors³⁾

Four-row linear recirculating ball bearing and guideway assemblies

Full complement

HIGH SPEED

HS, E-HS and N-HS carriages



Dimension table · Dimensions in mm

Designation	Dimensions				Mounting dimensions										
	$l_{\max}^{2)}$	H	B	L	A_1	J_B	b	A_2	L_1	L_s	J_L	J_{LZ}	j_L	$a_L, a_R^{3)}$	
							$\begin{matrix} -0,005 \\ -0,03 \end{matrix}$							min.	max.
KUVE25-B-HS	5 880	36	70	98,3	23,5	57	23	6,5	60,7	1,65	45	40	60	20	53
KUVE25-B-E-HS	5 880	33	73	98,3	25	60	23	6,5	60,7	1,65	35 ⁴⁾	60	20	53	
KUVE25-B-N-HS	5 880	31	70	98,3	23,5	57	23	6,5	60,7	1,65	45	40	60	20	53

For further table values, see page 346 and page 347.

① Locating face. ② Marking.

- 1) The stated torques represent maximum values for the secure transmission of forces in vibration-free, quasistatic applications ($S_0 = 1$). We recommend that the tightening torques for the screw connection of the adjacent construction should be determined at the customer under the conditions specific to the application and operation, observing the information in VDI Guideline 2230 Part 1 (2015) and the information in this description, see page 69 and page 26.
- 2) Maximum length of single-piece guideways.
Permissible number of guideway segments, see page 309.
- 3) a_L and a_R are dependent on the guideway length.
- 4) The central holes are not present in the case of KUVE25-B-E-HS. The outer holes do not have the thread G_2 .

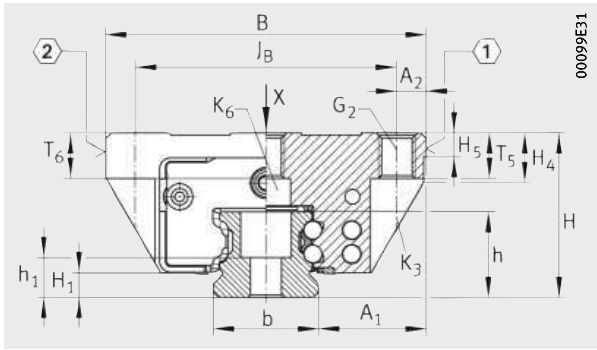

00099E31

KUVE25-B-HS, KUVE25-B-E-HS, KUVE25-B-N-HS

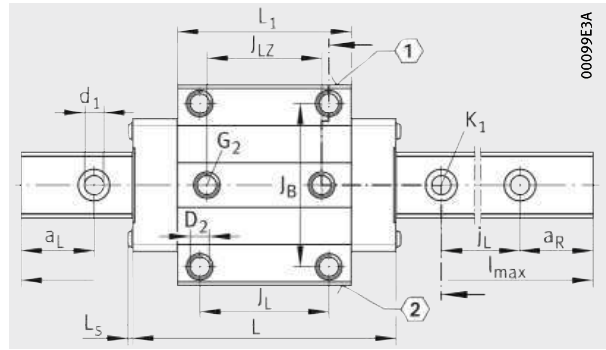

000609E3A

KUVE25-B-HS, KUVE25-B-E-HS, KUVE25-B-N-HS
View X rotated 90°

								Fixing screws ¹⁾										
H ₁	H ₄	H ₅	T ₅	T ₆	h	h ₁	DIN ISO 4762-12.9				DIN 7984-8.8				d ₁	D ₂		
							G ₂	K ₁		K ₃		K ₆		K ₆				
								M _A		M _A		M _A		M _A				M _A
5,1	10,9	5	10	10	18,7	8,7	M8	24	M6	17	M6	17	M6	17	–	–	6,8	6,7
5,1	7,85	5,25	10	⁴⁾ 10	18,7	8,7	⁴⁾ M8	⁴⁾ 24	M6	17	M6	17	⁴⁾ M6	⁴⁾ 17	⁴⁾ –	⁴⁾ –	6,8	–
5,1	9,3	5	10	8	18,7	8,7	M8	24	M6	17	M6	17	–	–	M6	8	6,8	6,7

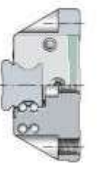

Four-row linear recirculating ball bearing and guideway assemblies

Full complement

HIGH SPEED

HS, E-HS and N-HS carriages



Dimension table (continued) · Dimensions in mm

Designation	Carriage		Guideway		Lubrication connectors		
	Designation	Mass m ≈ kg	Designation	Mass m ≈ kg/m	A ₃	G ₃	
							2)
KUVE25-B-HS	KWVE25-B-HS	0,71	TKVD25	2,7	11	M6	7
KUVE25-B-E-HS	KWVE25-B-E-HS	0,68	TKVD25	2,7	8	M6	7
KUVE25-B-N-HS	KWVE25-B-N-HS	0,57	TKVD25	2,7	6	M6	7

- 1) Calculation of basic load ratings in accordance with DIN ISO 14728-1.
Based on practical experience, it may be possible to increase the basic dynamic load rating.
The basic load rating can only be transmitted fully if the whole thread length is used and the adjacent construction is dimensioned appropriately.
- 2) Maximum permissible screw depth for lubrication connectors.
- 3) Lubrication connector S62 is included loose.

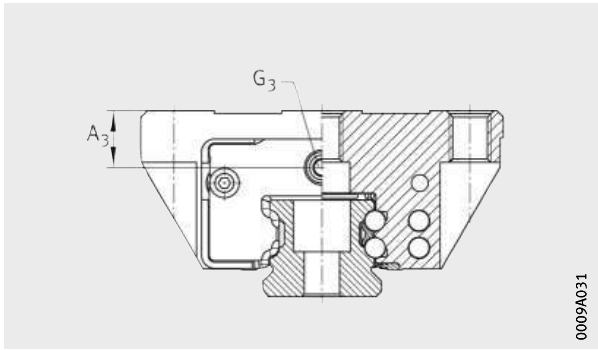

Lubrication connector on end face

0009A031

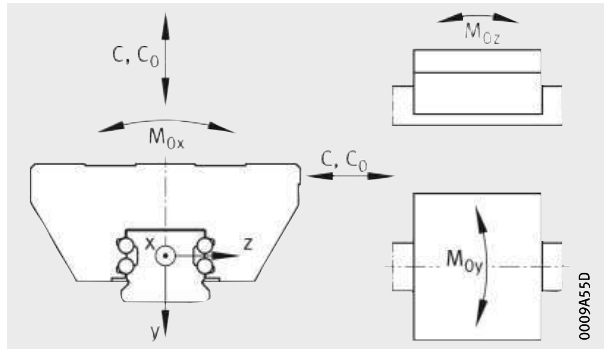

Load directions

0009A55D



Load carrying capacity

Basic load ratings¹⁾

Basic load ratings ¹⁾		Moment ratings		
dyn. C	stat. C ₀	M _{0x}	M _{0y}	M _{0z}
N	N	Nm	Nm	Nm
15 000	37 000	510	395	395
15 000	37 000	510	395	395
15 000	37 000	510	395	395

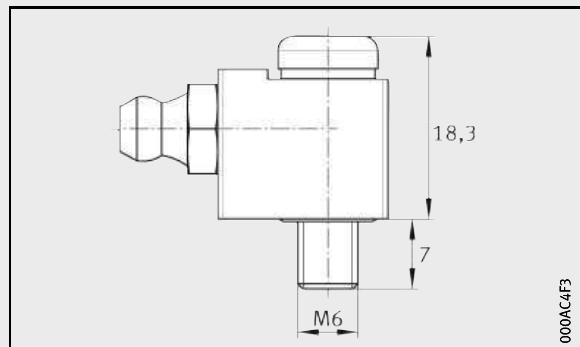

Lubrication connector S62³⁾

000AC4F3

Four-row linear recirculating ball bearing and guideway assemblies

Full complement

HIGH SPEED

ES-HS, H-HS, S-HS and SN-HS carriages



Dimension table · Dimensions in mm

Designation	Dimensions				Mounting dimensions					
	$l_{\max}^{2)}$	H	B	L	A_1	J_B	b -0,005 -0,03	A_2	L_1	L_5
KUVE25-B-ES-HS	5 880	33	48	98,3	12,5	35	23	6,5	60,7	1,65
KUVE25-B-H-HS	5 880	40	48	98,3	12,5	35	23	6,5	60,7	1,65
KUVE25-B-S-HS	5 880	36	48	98,3	12,5	35	23	6,5	60,7	1,65
KUVE25-B-SN-HS	5 880	31	48	98,3	12,5	35	23	6,5	60,7	1,65

For further table values, see page 350 and page 351.

① Locating face. ② Marking.

- 1) The stated torques represent maximum values for the secure transmission of forces in vibration-free, quasistatic applications ($S_0 = 1$). We recommend that the tightening torques for the screw connection of the adjacent construction should be determined at the customer under the conditions specific to the application and operation, observing the information in VDI Guideline 2230 Part 1 (2015) and the information in this description, see page 69 and page 26.
- 2) Maximum length of single-piece guideways.
Permissible number of guideway segments, see page 309.
Maximum single-piece guideway length of 6 m available by agreement.
- 3) a_L and a_R are dependent on the guideway length.

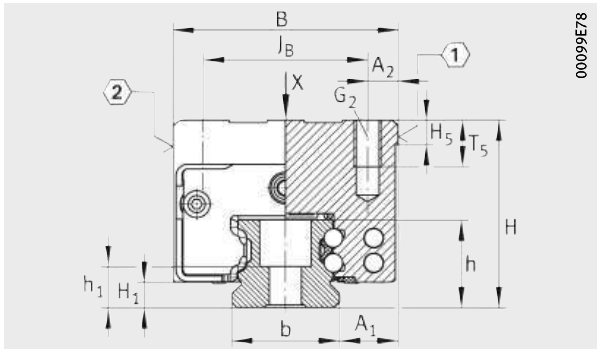

00099E78

KUVE25-B-ES-HS, KUVE25-B-H-HS, KUVE25-B-S-HS, KUVE25-B-SN-HS

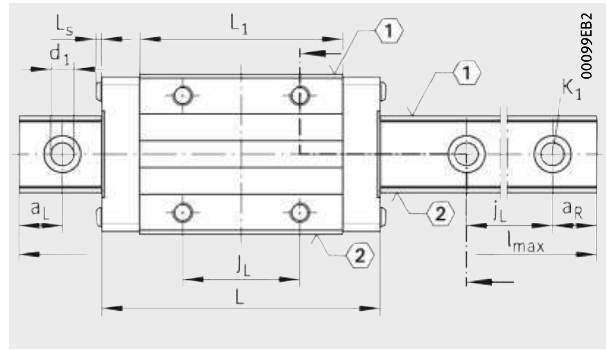

00099E82

KUVE25-B-ES-HS, KUVE25-B-H-HS, KUVE25-B-S-HS, KUVE25-B-SN-HS
View X rotated 90°

									Fixing screws ¹⁾				
J _L	j _L	a _L , a _R ³⁾		H ₁	H ₅	T ₅	h	h ₁	G ₂		K ₁		d ₁
		DIN ISO 4762-12.9											
		min.	max.						M _A Nm		M _A Nm		
35	60	20	53	5,2	5,25	10	18,7	8,2	M6	17	M6	17	6,8
35	60	20	53	5,1	5	10	18,7	8,7	M6	10	M6	17	6,8
35	60	20	53	5,1	5	10	18,7	8,7	M6	10	M6	17	6,8
35	60	20	53	5,1	5	7,5	18,7	8,7	M6	10	M6	17	6,8

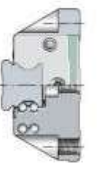

Four-row linear recirculating ball bearing and guideway assemblies

Full complement

HIGH SPEED

ES-HS, H-HS, S-HS and SN-HS carriages



Dimension table (continued) · Dimensions in mm

Designation	Carriage		Guideway		Lubrication connectors		
	Designation	Mass m ≈ kg	Designation	Mass m ≈ kg/m	A ₃	G ₃	
							²⁾
KUVE25-B-ES-HS	KWVE25-B-ES-HS	0,56	TKVD25	2,7	11	M6	7
KUVE25-B-H-HS	KWVE25-B-H-HS	0,65	TKVD25	2,7	15	M6	7
KUVE25-B-S-HS	KWVE25-B-S-HS	0,56	TKVD25	2,7	11	M6	7
KUVE25-B-SN-HS	KWVE25-B-SN-HS	0,45	TKVD25	2,7	6	M6	7

¹⁾ Calculation of basic load ratings in accordance with DIN ISO 14728-1.

Based on practical experience, it may be possible to increase the basic dynamic load rating. The basic load rating can only be transmitted fully if the whole thread length is used and the adjacent construction is dimensioned appropriately.

²⁾ Maximum permissible screw depth for lubrication connectors.

³⁾ Lubrication connector S62 is included loose.

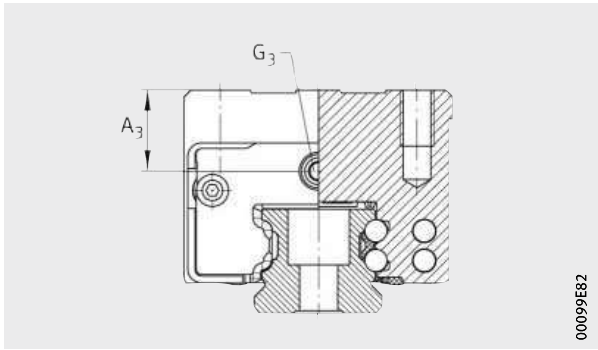

Lubrication connector on end face

00099E82

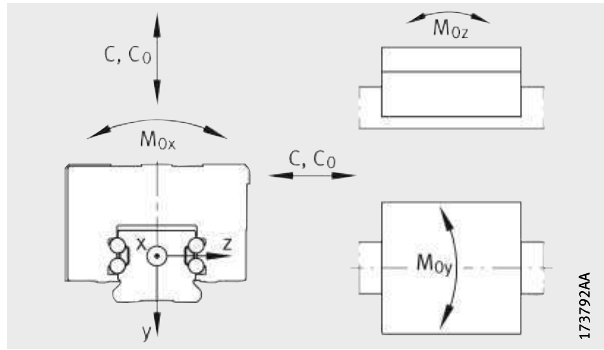

Load directions

173792AA

Load carrying capacity

Basic load ratings¹⁾

Basic load ratings ¹⁾		Moment ratings		
dyn. C	stat. C ₀	M _{0x}	M _{0y}	M _{0z}
N	N	Nm	Nm	Nm
15 000	37 000	510	395	395
15 000	37 000	510	395	395
15 000	37 000	510	395	395
15 000	37 000	510	395	395

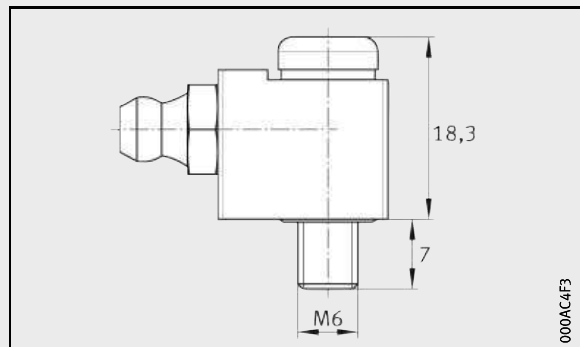
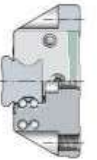

Lubrication connector S62³⁾

000AC4F3

Four-row linear recirculating ball bearing and guideway assemblies

Guideways and closing methods for
KUVE...-B
KUVE...-W

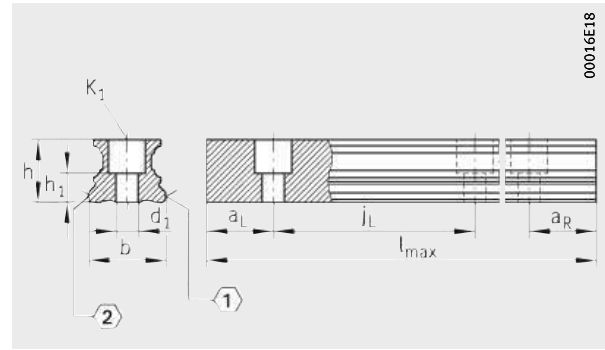

TKVD

Dimension table · Dimensions in mm

Designation	For linear guidance system	Mass m ≈ kg/m	Closing plug ¹⁾				Covering strip ²⁾					
			Plastic		Brass		Adhesive bonded	Clip fit Convex	Retaining plate			
			one-piece	two-piece ⁶⁾	one-piece	two-piece						
TKVD15-B	KUVE15-B	1,44	KA07-A-TN	KA07-A-TN/A	-	KA07-M/A	-	-	-			
TKVD15-B-U			-	-		-						
TKVD15-W	KUVE15-W	3,6	KA08-TN	KA08-TN/A	-	-	-	-	-			
TKVD15-W-U			-	-						-		
TKVD20	KUVE20-B	2,2	KA10-TN	KA10-TN/A	KA10-M	KA10-M/A	-	-	-			
TKVD20-U			-	-	-	-						
TKVD20-ADB			-	-	-	-				ADB13	-	HPL.ADB9-B
TKVD20-ADK			-	-	-	-				ADK12		
TKVD20-W	KUVE20-W	5	KA08-TN	KA08-TN/A	-	-	-	-	-			
TKVD20-W-U			-	-						-	-	

① Locating face. ② Marking.

1) Closing plugs, see page 401.

2) Covering strips, see page 402.

3) The stated torques represent maximum values for the secure transmission of forces in vibration-free, quasistatic applications ($S_0 = 1$). We recommend that the tightening torques for the screw connection of the adjacent construction should be determined at the customer under the conditions specific to the application and operation, observing the information in VDI Guideline 2230 Part 1 (2015) and the information in this description, see page 69 and page 26.

4) Maximum length of single-piece guideways.
Longer guideways are supplied as several segments and are marked accordingly.
Permissible number of guideway segments, see page 309.

5) a_L and a_R are dependent on the guideway length.

6) Standard.

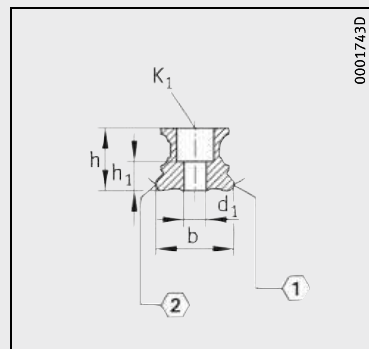

TKVD

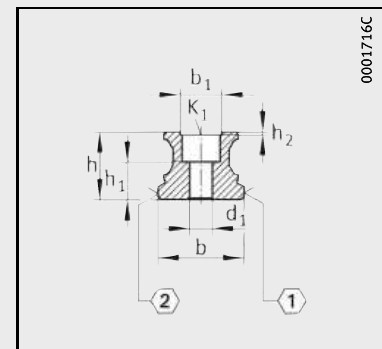

TKVD...-ADB

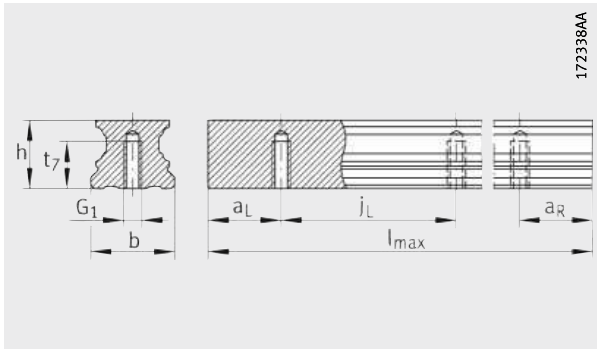

TKVD..-U

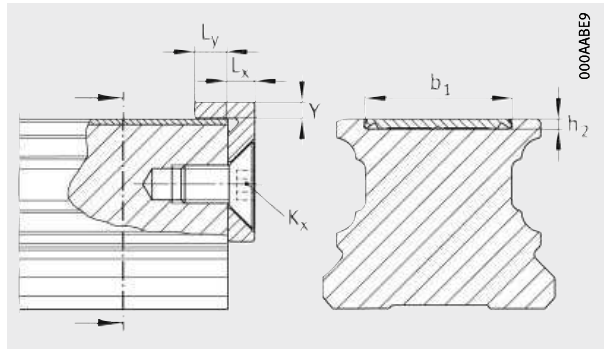

Retaining plate and covering strip

Dimensions

Fixing screws³⁾

K _x	L _x	L _y	Y	l _{max} ⁴⁾	h	b	a _L , a _R ⁵⁾		j _L	j _B	a ₅	h ₁	h ₂	t ₇	b ₁	DIN ISO 4762-12.9			d ₁	
							min.	max.								K ₁				
																M _A Nm	M _A Nm			
-	-	-	-	2880	15	15	20	53	60	-	-	7,7	-	-	-	-	-	M4	5	4,6
-	-	-	-	2890	12,9	37	10	44	50	22	7,5	6	-	-	-	-	-	M4	5	4,6
-	-	-	-	5880	17	20	20	53	60	-	-	8,6	-	-	-	-	-	M5	10	5,8
M5	4	5	2	5880	17	20	20	53	60	-	-	8,6	0,5 1,1	-	13 12,6	-	-	M5	10	5,8
-	-	-	-	2880	17	42	20	53	60	24	9	10	-	-	-	-	-	M4	5	5,8
-	-	-	-	2880	17	42	20	53	60	24	9	10	-	10	-	-	-	M6	17	-

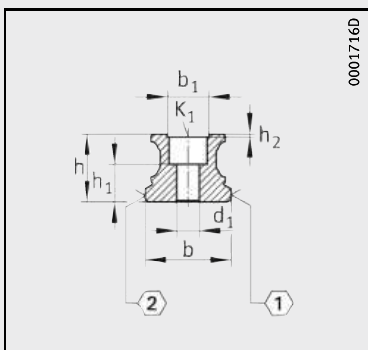
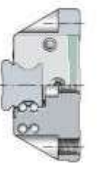

TKVD..-ADK

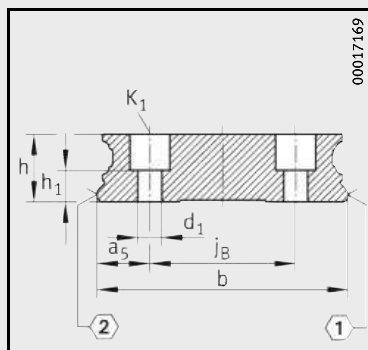

TKVD..-W

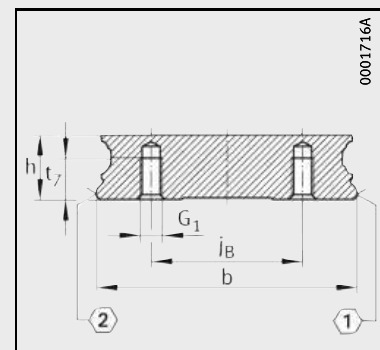

TKVD..-W-U

Four-row linear recirculating ball bearing and guideway assemblies

Guideways and closing methods for
KUVE...-B
KUVE...-W

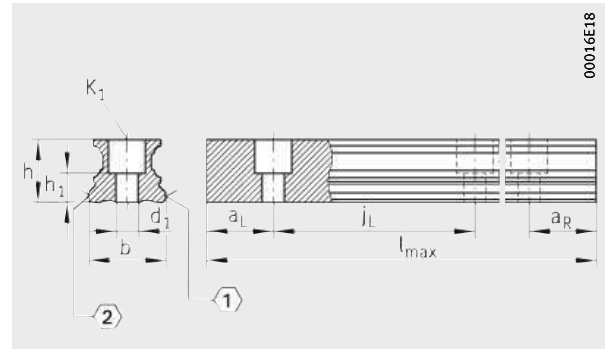

TKVD

Dimension table (continued) · Dimensions in mm

Designation	For linear guidance system	Mass m ≈ kg/m	Closing plug ¹⁾				Covering strip ²⁾		
			Plastic		Brass		Adhesive bonded	Clip fit Convex	Retaining plate
			one-piece	two-piece ⁶⁾	one-piece	two-piece			
TKVD25	KUVE25-B	2,7	KA11-TN	KA11-TN/A	KA11-M	KA11-M/A	-	-	-
TKVD25-U			-	-	-	-	-	-	-
TKVD25-ADB		2,7	-	-	-	-	ADB13	-	HPL.ADB9-B
TKVD25-ADK			-	-	-	-	-	ADK12	
TKVD25-W	KUVE25-W	9,4	KA11-TN	KA11-TN/A	-	-	-	-	-
TKVD25-W-U			-	-	-	-	-	-	-

① Locating face. ② Marking.

1) Closing plugs, see page 401.

2) Covering strips, see page 402.

3) The stated torques represent maximum values for the secure transmission of forces in vibration-free, quasistatic applications ($S_0 = 1$). We recommend that the tightening torques for the screw connection of the adjacent construction should be determined at the customer under the conditions specific to the application and operation, observing the information in VDI Guideline 2230 Part 1 (2015) and the information in this description, see page 69 and page 26.

4) Maximum length of single-piece guideways.
Longer guideways are supplied as several segments and are marked accordingly.
Permissible number of guideway segments, see page 309.

5) a_L and a_R are dependent on the guideway length.

6) Standard.

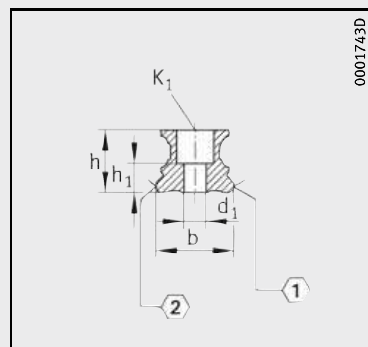

TKVD

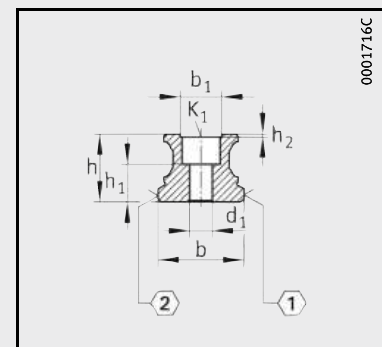

TKVD...-ADB

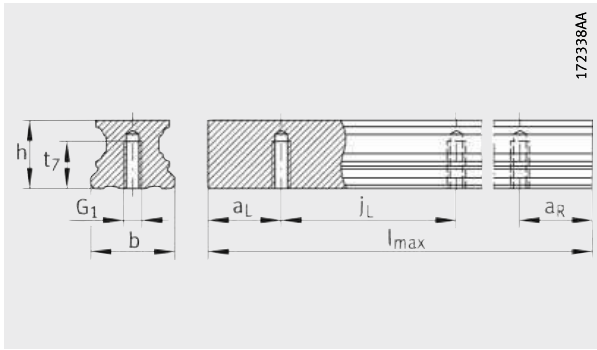

TKVD..-U

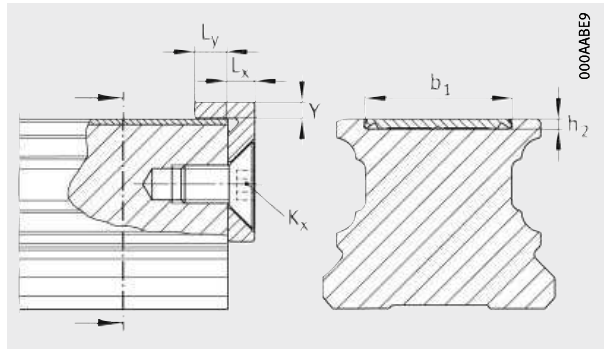

Retaining plate and covering strip

Dimensions															Fixing screws ³⁾					
K _x	L _x	L _y	Y	l _{max} ⁴⁾	h	b	a _L , a _R ⁵⁾		j _L	j _B	a ₅	h ₁	h ₂	t ₇	b ₁	G ₁		K ₁		d ₁
							DIN ISO 4762-12.9									M _A	M _A			
																		Nm	Nm	
				±0,5																
-	-	-	-	5 880	18,7	23	20	53	60	-	-	8,2	-	-	-	-	-	M6	17	6,8
													12			M6	17	-	-	-
M5	4	5	2	5 880	18,7	23	20	53	60	-	-	8,2	0,5 1,1	-	13 12,6	-	-	M6	17	6,8
-	-	-	-	5 860	18,7	69	20	71	80	40	14,5	8,2	-	-	-	-	-	M6	17	6,8
													12			M6	17	-	-	-

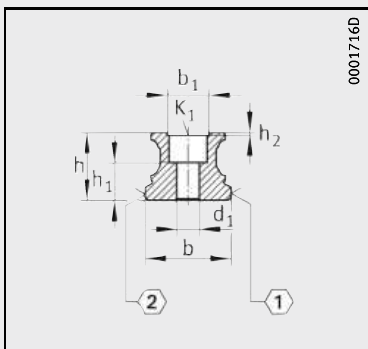
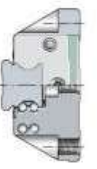

TKVD..-ADK

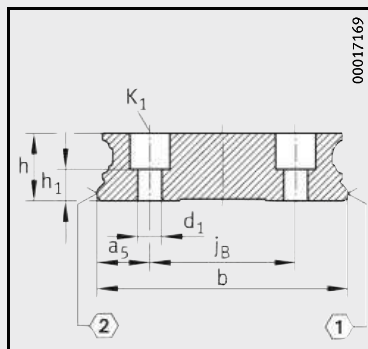

TKVD..-W

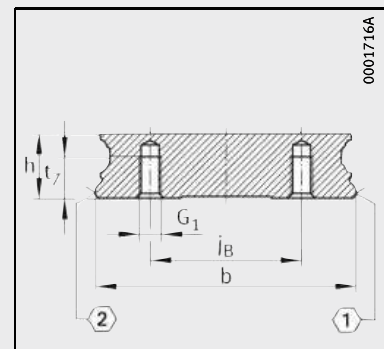

TKVD..-W-U

Four-row linear recirculating ball bearing and guideway assemblies

Guideways and closing methods for
KUVE...-B
KUVE...-W

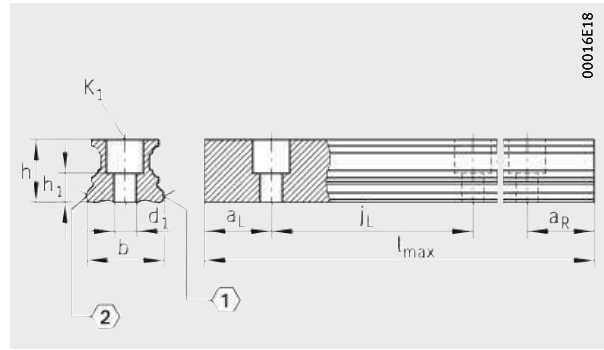

TKVD

Dimension table (continued) · Dimensions in mm

Designation	For linear guidance system	Mass m ≈ kg/m	Closing plug ¹⁾				Covering strip ²⁾		
			Plastic		Brass		Adhesive bonded	Clip fit Convex	Retaining plate
			one-piece	two-piece ⁶⁾	one-piece	two-piece			
TKVD30	KUVE30-B	4,3	KA15-TN	KA15-TN/A	KA15-M	KA15-M/A	-	-	-
TKVD30-U			-	-	-	-	-	-	-
TKVD30-ADB		4,3	-	-	-	-	ADB18	-	HPL.ADB17-B
TKVD30-ADK	-		-	-	-	-	ADK16		
TKVD30-W	KUVE30-W	13,6	KA15TN	KA15TN/A	-	-	-	-	-
TKVD30-W-U			-	-	-	-	-	-	-

① Locating face. ② Marking.

1) Closing plugs, see page 401.

2) Covering strips, see page 402.

3) The stated torques represent maximum values for the secure transmission of forces in vibration-free, quasistatic applications ($S_0 = 1$). We recommend that the tightening torques for the screw connection of the adjacent construction should be determined at the customer under the conditions specific to the application and operation, observing the information in VDI Guideline 2230 Part 1 (2015) and the information in this description, see page 69 and page 26.

4) Maximum length of single-piece guideways.
Longer guideways are supplied as several segments and are marked accordingly.
Permissible number of guideway segments, see page 309.

5) a_L and a_R are dependent on the guideway length.

6) Standard.

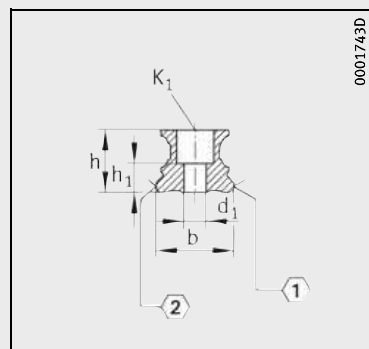

TKVD

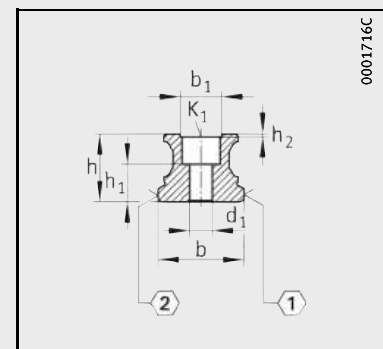

TKVD...-ADB

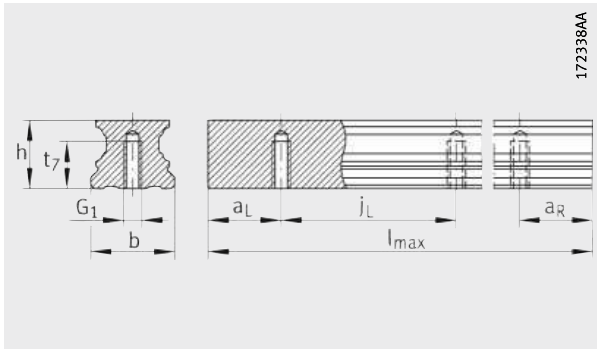

TKVD..-U

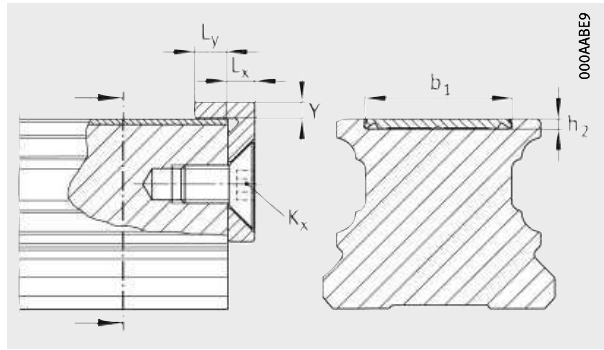

Retaining plate and covering strip

Dimensions															Fixing screws ³⁾						
K _x	L _x	L _y	Y	l _{max} ⁴⁾	h	b	a _L , a _R ⁵⁾		j _L	j _B	a ₅	h ₁	h ₂	t ₇	b ₁	G ₁		K ₁		d ₁	
							DIN ISO 4762-12.9									M _A	M _A				
																		Nm	Nm		
-	-	-	-	5 860	23,5	28	20	71	80	-	-	11	-	-	-	-	-	M8	41	9	
							-0,005 -0,035	min.	min.			±0,5									
M6	4	5	3	5 860	23,5	28	20	71	80	-	-	11	0,5 1,1	-	18 16,6	-	-	M8	41	9	
-	-	-	-	5 860	23,5	80	20	71	80	50	15	11	-	15	-	-	M8	41	-	-	9

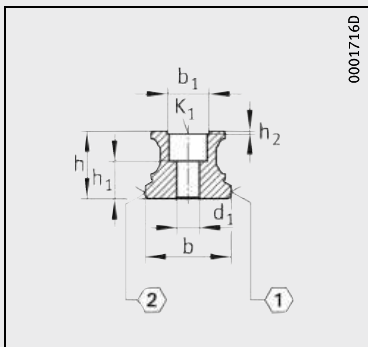
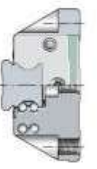

TKVD..-ADK

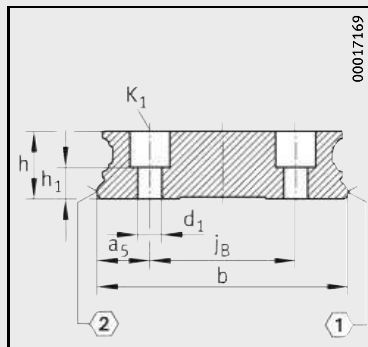

TKVD..-W

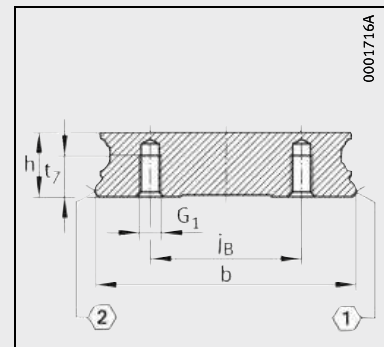

TKVD..-W-U

Four-row linear recirculating ball bearing and guideway assemblies

Guideways and closing methods for
KUVE...-B
KUVE...-W

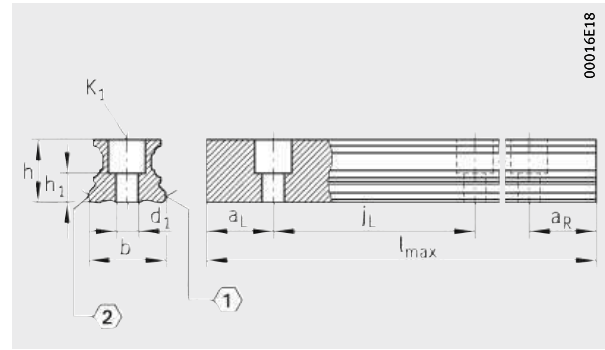

TKVD

Dimension table (continued) · Dimensions in mm

Designation	For linear guidance system	Mass m ≈ kg/m	Closing plug ¹⁾				Covering strip ²⁾		
			Plastic		Brass		Adhesive bonded	Clip fit Convex	Retaining plate
			one-piece	two-piece ⁶⁾	one-piece	two-piece			
TKVD35	KUVE35-B	5,7	KA15-TN	KA15-TN/A	KA15-M	KA15-M/A	-	-	-
TKVD35-U			-	-	-	-	-	-	-
TKVD35-ADB		5,7	-	-	-	-	ADB18	-	HPL.ADB17-B
TKVD35-ADK			-	-	-	-	-	ADK16	
TKVD35-W	KUVE35-W	17,4	KA15-TN	KA15-TN/A	-	-	-	-	-
TKVD35-W-U			-	-	-	-	-	-	-

① Locating face. ② Marking.

1) Closing plugs, see page 401.

2) Covering strips, see page 402.

3) The stated torques represent maximum values for the secure transmission of forces in vibration-free, quasistatic applications ($S_0 = 1$). We recommend that the tightening torques for the screw connection of the adjacent construction should be determined at the customer under the conditions specific to the application and operation, observing the information in VDI Guideline 2230 Part 1 (2015) and the information in this description, see page 69 and page 26.

4) Maximum length of single-piece guideways.
Longer guideways are supplied as several segments and are marked accordingly.
Permissible number of guideway segments, see page 309.

5) a_L and a_R are dependent on the guideway length.

6) Standard.

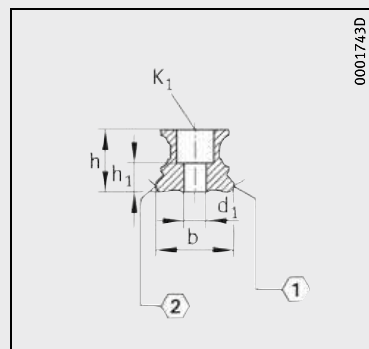

TKVD

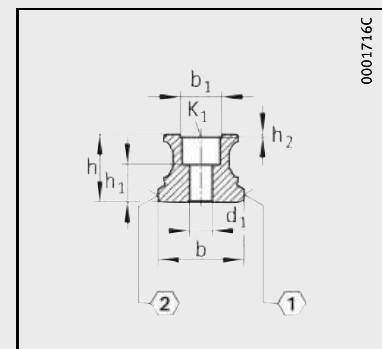

TKVD..-ADB

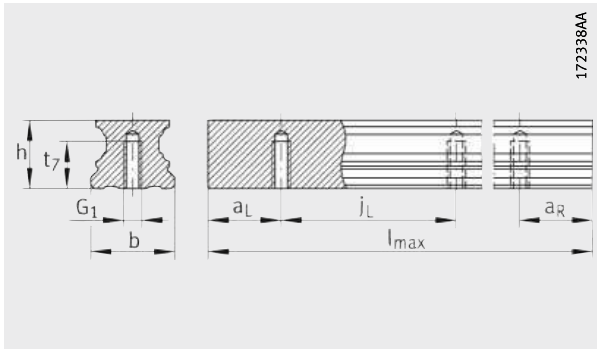

TKVD..-U

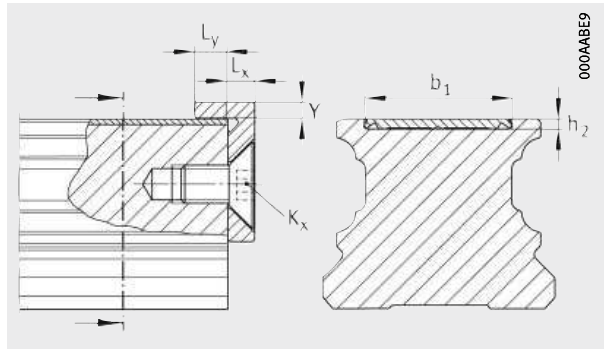

Retaining plate and covering strip

Dimensions

Fixing screws³⁾

K _x	L _x	L _y	Y	l _{max} ⁴⁾	h	b	a _L , a _R ⁵⁾		j _L	j _B	a ₅	h ₁	h ₂	t ₇	b ₁	DIN ISO 4762-12.9			d ₁	
							min.	max.								G ₁	K ₁			
																	M _A	M _A		
-	-	-	-	5 860	27	34	20	71	80	-	-	14,5	-	-	-	-	-	M8	41	9
M6	4	5	3	5 860	27	34	20	71	80	-	-	14,5	0,5 1,1	-	18 16,6	-	-	M8	41	9
-	-	-	-	5 860	27	90	20	71	80	60	15	14,5	-	-	-	-	-	M8	41	9

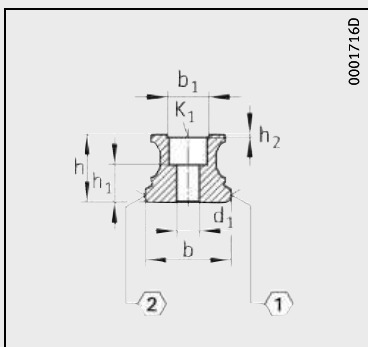
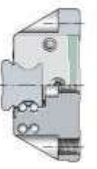

TKVD..-ADK

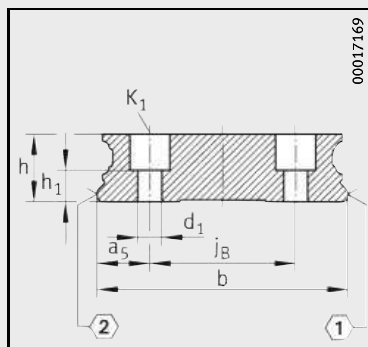

TKVD..-W

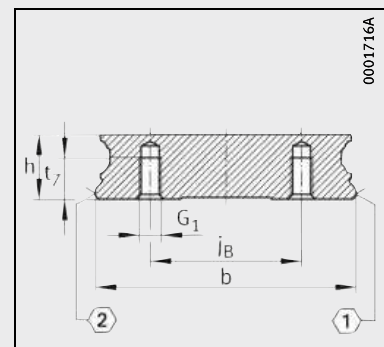

TKVD..-W-U

Four-row linear recirculating ball bearing and guideway assemblies

Guideways and closing methods for KUVE...-B

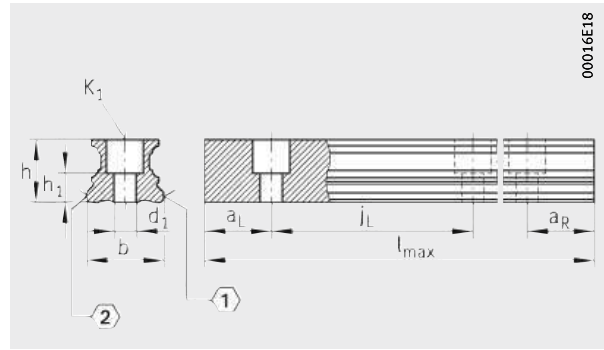

TKVD

Dimension table (continued) · Dimensions in mm

Designation	For linear guidance system	Mass m ≈ kg/m	Closing plug ¹⁾				Covering strip ²⁾		
			Plastic		Brass		Adhesive bonded	Clip fit Convex	Retaining plate
			one-piece	two-piece ⁶⁾	one-piece	two-piece			
TKVD45	KUVE45-B	9,2	KA20-TN	KA20-TN/A	KA20-M	KA20-M/A	–	–	–
TKVD45-U			–	–	–	–	–	–	–
TKVD45-ADB		9,2	–	–	–	–	ADB23	–	HPL.ADB17-B
TKVD45-ADK			–	–	–	–	–	ADK21	
TKVD55-B	KUVE55-B	14	KA24-TN	KA24-TN/A	KA24-M	KA24-M/A	–	–	–
TKVD55-B-U			–	–	–	–	–	–	–
TKVD55-ADB		14	–	–	–	–	ADB27	–	HPL.ADB17-B
TKVD55-ADK			–	–	–	–	–	ADK25	

① Locating face. ② Marking.

1) Closing plugs, see page 401.

2) Covering strips, see page 402.

3) The stated torques represent maximum values for the secure transmission of forces in vibration-free, quasistatic applications ($S_0 = 1$). We recommend that the tightening torques for the screw connection of the adjacent construction should be determined at the customer under the conditions specific to the application and operation, observing the information in VDI Guideline 2230 Part 1 (2015) and the information in this description, see page 69 and page 26.

4) Maximum length of single-piece guideways.
Longer guideways are supplied as several segments and are marked accordingly.
Permissible number of guideway segments, see page 309.

5) a_L and a_R are dependent on the guideway length.

6) Standard.

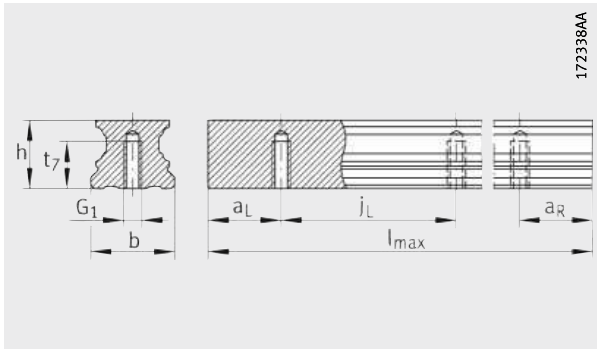

TKVD..-U

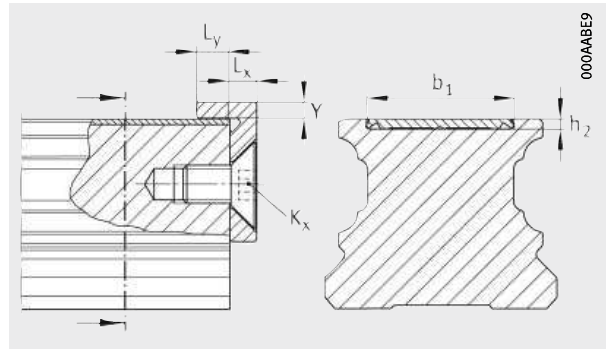

Retaining plate and covering strip

Dimensions

Fixing screws³⁾

K _x	L _x	L _y	Y	l _{max} ⁴⁾	h	b	a _L , a _R ⁵⁾		j _L	j _B	a ₅	h ₁	h ₂	t ₇	b ₁	DIN ISO 4762-12.9			d ₁	
							min.	max.								G ₁		K ₁		
																M _A	Nm	M _A		Nm
-	-	-	-	5835	34,2	45	20	94	105	-	-	15,7	-	-	-	-	-	M12	140	13,4
M5	4	5	2	5835	34,2	45	20	94	105	-	-	15,7	0,5 1,1	-	23 21,7	-	-	M12	140	13,4
-	-	-	-	5820	41,5	53	20	107	120	-	-	19	-	-	-	-	-	M14	220	15,4
M5	4	5	2	5820	41,5	53	20	107	120	-	-	19	0,5 1,1	-	27 25,7	-	-	M14	220	15,4

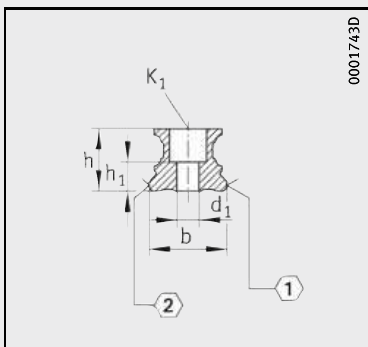
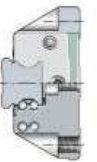

TKVD

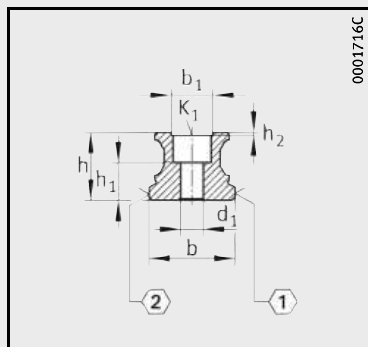

TKVD..-ADB

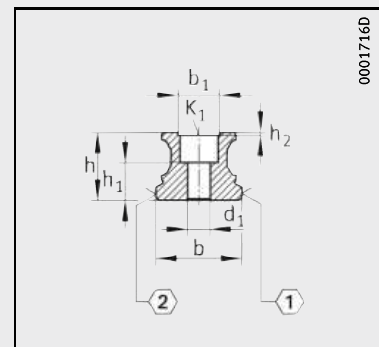

TKVD..-ADK